



SKA SA - SQUARE KILOMETRE ARRAY PROJECT

BID REFERENCE: SKA SA HERA 001 2017

THE SUPPLY, MANUFACTURE AND DELIVERY OF PVC PARTS OVER FOUR STAGED DELIVERIES TO THE SKA SA LOSBERG SITE NEAR THE TOWN OF CARNARVON, NORTHERN CAPE

BID INVITATION NOTICE

The South African Square Kilometre Array (SKA) project, which includes the construction of the MeerKAT radio telescope in the Karoo, is a project of the Department of Science and Technology, executed through the National Research Foundation and the SKA SA. Information about the project is available from www.ska.ac.za.

Tenders are hereby invited for THE SUPPLY, MANUFACTURE AND DELIVERY OF PVC PARTS OVER FOUR STAGED DELIVERIES TO THE SKA SA LOSBERG SITE NEAR THE TOWN OF CARNARVON, NORTHERN CAPE.

Sealed tenders marked, BID REFERENCE: SKA SA HERA 001 2017 THE SUPPLY, MANUFACTURE AND DELIVERY OF PVC PARTS OVER FOUR STAGED DELIVERIES TO THE SKA SA LOSBERG SITE NEAR THE TOWN OF CARNARVON, NORTHERN CAPE, must be placed in the tender box at SKA SA Pinelands 3rd Floor, The Park, Park Road, Pinelands, Cape Town, 7405 on or before **11:00 on 2 May 2017**.

Telegraphic, telephonic, facsimile, email and late tenders will not be accepted.

Bid documentation will be obtainable at SKA SA website at <http://www.ska.ac.za/tenders/>

For queries, or to obtain additional information, contact the **Supply Chain Specialist, Mr Rayyan Arnold**, at rarnold@ska.ac.za or telephone number (021) 506 7415.



**National
Research
Foundation**

INVITATION TO BID (SBD 1) on procurement requirements

YOU ARE HEREBY INVITED TO BID FOR THE FOLLOWING SPECIFIED SUPPLY REQUIREMENTS

BID NUMBER	SKA SA HERA 001/2017
-------------------	----------------------

CLOSING DATE AND TIME	2 May 2017 @ 11:00
------------------------------	--------------------

BID DESCRIPTION

THE SUPPLY, MANUFACTURE AND DELIVERY OF PVC PARTS OVER FOUR STAGED DELIVERIES TO THE SKA SA LOSBERG SITE NEAR THE TOWN OF CARNARVON, NORTHERN CAPE

Bidders must sign the signature page of the form SBD1 validating all documents included in the response to this invitation.

The successful bidder and the NRF will sign the written Contract Form (SBD 7) once the delegated authority has approved the award of such contract.

Preferential Procurement System Applicable:	80:20
---	--------------

Validity Period From Date Of Closure:	150 days
---------------------------------------	-----------------

BID DOCUMENTS ARE TO BE DEPOSITED IN THE BID BOX AT:

PHYSICAL ADDRESS

Bid Box at Reception
Third Floor, The Park, Park Road,
Pinelands 7405

Bid Box open from 8 am to 4.30 p.m.
Monday to Friday

ADDRESSED AS FOLLOWS:

On the face of each envelope, the Bid Number and Bidder's Name, Postal Address, Contact Name, Telephone Number and email address

	<p>BIDDERS ARE REQUIRED TO DELIVER THEIR BID TO THE CORRECT ADDRESS TIMEOUSLY IN ORDER FOR THE NRF TO CONSIDER IT. THE NRF WILL NOT CONSIDER ANY BIDS RECEIVED LATER THAN THE CLOSING DATE AND TIME NOR RETURN THESE TO THE BIDDER.</p>	
	<p>Bidders must submit their bid response on the official bid invitation forms (not to be re-typed) with additional information provided on attached supporting schedules. The NRF provides the checklist “Returnable Documents” of all required documentation with certain documentation mandatory for entering the evaluation phase.</p> <p>Non-submission of these marked documents will lead to disqualification of the bidder.</p>	
	<p>THIS BID IS SUBJECT TO THE PREFERENTIAL PROCUREMENT POLICY FRAMEWORK ACT AND THE PREFERENTIAL PROCUREMENT REGULATIONS – 2017 AS AMENDED.</p> <p>THIS BID IS SUBJECT TO THE GENERAL CONDITIONS OF CONTRACT AND SPECIAL CONDITIONS OF CONTRACT STIPULATED IN THIS DOCUMENT. THE BIDDER READ AND ACCEPTED THESE CONDITIONS OF CONTRACT HAS EVIDENCED BY THE BIDDER’S SIGNATURE ON EACH PAGE.</p>	
	<p>REGISTRATION ON THE CENTRAL SUPPLIER DATABASE (CSD):</p> <p>The bidder is required to be registered on the National Treasury’s Central Supplier Database in order to do business with the NRF and for the NRF to award a bid and to sign the subsequent contract. The NRF is an organ of state. Registration on the CSD (www.csd.gov.za) is compulsory and bids from unregistered bidders are not considered.</p> <p>National Treasury Contact Details: 012 406 9222 or email csd.support@treasury.gov.za</p>	
<p>SETS OF BID DOCUMENTS REQUIRED:</p>		
	<p>Number of ORIGINAL documents for contract signing</p>	<p>2</p>
	<p>Bidders must submit the bid in hard copy format (paper document) to the NRF. The hard copy of these original sets of bid documents including the bidder’s response to the specification, the bidder’s pricing, and the SBD 7, (contract signature page signed by both parties), serve as the legal bid contract document and the master record between the bidder and the NRF. The bidders attach the originals or certified copies of any certificates stipulated in this document to these original sets of bid documents.</p> <p>Any discrepancy between the evaluation copies and the master record, the master record will prevail. Any discrepancy between the original sets deposited with the NRF and that</p>	

kept by the bidder, the original set deposited with the NRF is the master contract for both parties.	
Number of EVALUATION copies (on a flash drive, including all supporting documentation, excluding pricing information):	1
Bidders mark documents as either “ Original ” or “ Copy for evaluation ” and number all pages sequentially. Bidders group documents into “PROPOSAL” and “PRICING” Sections.	
Two envelope system required	YES
<p>The objective for the use of the two-envelope system is to evaluate the Proposals Section without reference to the Price Section ensuring both sections are evaluated fairly and unbiased.</p> <p>The first envelope holds all documents excluding the SBD3 (price summary schedule) and detailed supporting pricing documentation. The second envelope holds the SBD3 and the detailed supporting pricing documentation. An outer envelope encloses both envelopes that have the envelope addressing as stated in this document.</p> <p>The NRF only opens the proposal – the first envelope – at the evaluation stage and only opens the pricing – the second envelope – for those bidders who meet the predefined threshold at the proposal evaluation.</p>	
ENQUIRIES CAN BE DIRECTED TO THE FOLLOWING	
TECHNICAL ENQUIRIES	SUPPLY CHAIN MANAGEMENT ENQUIRIES
Kathryn Rosie (krosie@ska.ac.za) Tel: 021 506 7300	Rayyan Arnold (rarnold@ska.ac.za) Tel: 021 506 7300

TABLE OF CONTENTS

BID DESCRIPTION.....	1
SETS OF BID DOCUMENTS REQUIRED:.....	2
ENQUIRIES CAN BE DIRECTED TO THE FOLLOWING	3
INTRODUCTION TO THE NRF	5
INTRODUCTION TO THE NRF BUSINESS UNIT RESPONSIBLE FOR THIS BID.....	5
CONTEXT OF THIS PROCUREMENT.....	6
RETURNABLE DOCUMENT CHECKLIST TO QUALIFY FOR EVALUATION	6
THE BIDDING PROCESS	8
EVALUATION CRITERIA FOR EVALUATING BIDDERS RESPONSES.....	11
THE BIDDERS PARTICULARS.....	14
CONTRACT PERIOD.....	17
SCOPE OF WORK.....	17
SPECIAL CONDITIONS FOR MANAGING THE CONTRACTUAL OBLIGATIONS.....	19
PRICING DETAIL.....	21
PREFERENCE POINTS CLAIMED (SBD 6.1).....	26
DUE DILIGENCE REQUIREMENTS	29
GENERAL CONDITIONS OF CONTRACT (With amendments to these as separate SPECIAL CONDITIONS).....	34
REFERENCE LETTER ANNEXURE	52
BID SUBMISSION CERTIFICATE FORM - (SBD 1).....	54

INTRODUCTION TO THE NRF

The National Research Foundation (“NRF”) is a juristic person established in terms of the National Research Foundation Act, Act 23 of 1998, and a Schedule 3A Public Entity in terms of the Public Finance Management Act.

The NRF is the government’s national agency responsible for promoting and supporting research and human capital development through funding researchers, provision of the National Research Platforms, and science outreach platforms/programs to the broader community. The NRF provides these services in all fields of science and technology, including natural science, engineering, social science, and humanities.

The NRF delivers its mandate through its internal business units which are both functional and geographically diverse. Unless specifically noted, all contracts flowing from bidding apply to all of its business units.

INTRODUCTION TO THE NRF BUSINESS UNIT RESPONSIBLE FOR THIS BID

The business unit SKA SA is a multi-disciplinary research facility for research in the field of radio astronomy with its primary function is focused on construction of radio telescopes in the Karoo and promoting its research fields in southern Africa.

The SKA SA Losberg site in the Karoo is host to the Square Kilometre Array, MeerKAT, and KAT-7 radio telescope installations, as well as the HERA experiment.

Additionally, the site hosts a number of guest instruments from other institutions, including the PAPER experiment, which was in operation from 2009 – 2015. This consisted of 128 low frequency dipole antennas housed in ground-based trough reflectors.

SKA SA is currently constructing the low frequency Hydrogen Epoch of Reionization Array (HERA) on the pre-existing PAPER site, which will consist of up to 350 14m dishes, constructed from low-cost building materials. The PAPER and HERA experiments are both project managed out of the University of California at Berkeley, with partner institutions across the United States, the UK, Italy, and South Africa. 37 antennas have been constructed as part of precursor build programmes. An array of 240 antennas is expected to be in operation by the end of 2018.

The location of HERA on the SKA SA Karoo site is located at 30°43'15"S, 21°25'40"E (GPS coordinates).

CONTEXT OF THIS PROCUREMENT

The reflector support structure for the HERA dishes is made up of PVC pressure pipe cut to various specifications – these form the ‘shape’ of the dish and can be seen as blue radial spars in Figure 1. The specifications contained herein have been qualified during the precursor build phases.

The buildout of the antennas which make up the HERA experiment is due to increase at a rapid rate in 2017. To ensure consistency of construction material supply, this supply tender requests the supply, manufacture, and delivery of various PVC parts fabricated according to the specifications detailed in this document and delivered to the SKA SA Losberg site in 4 nominally equal staged quantities.

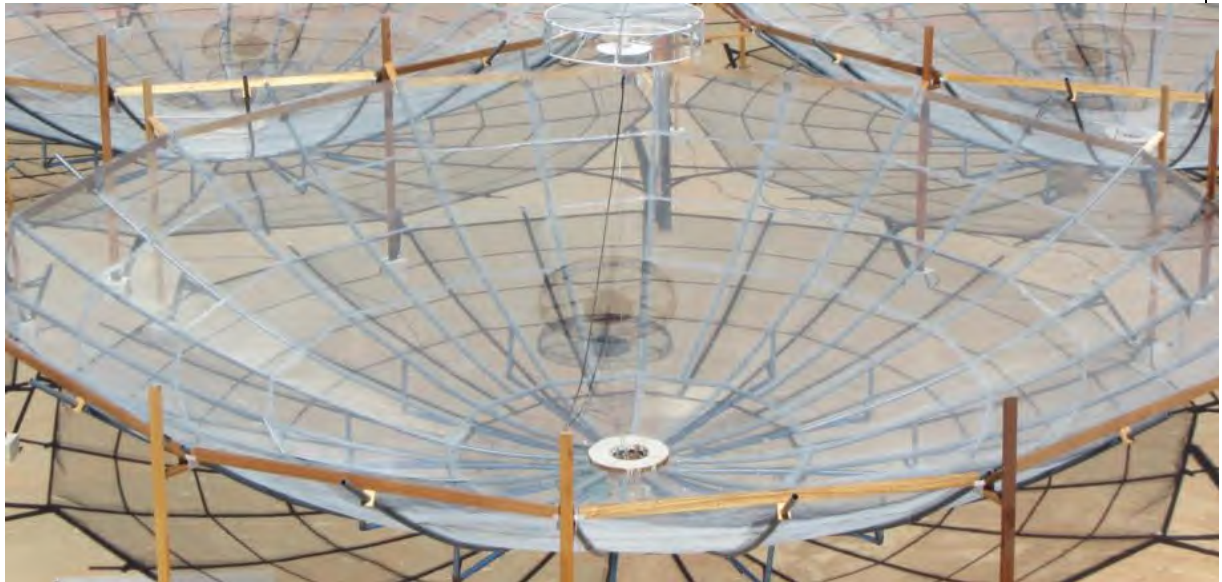

Figure 1: One of the HERA prototype dishes

RETURNABLE DOCUMENT CHECKLIST TO QUALIFY FOR EVALUATION

RETURNABLE DOCUMENTS	Envelope 1			
(M = Mandatory (Go/No GO))				Bid Section Reference
Signed and completed Procurement Invitation (SBD 1) including the SBD 4, 6.1, 8 and 9	M	YES	NO	
Response to the specification in this invitation	M	YES	NO	

Evidence of capacity to execute this bid and subsequent contract i.e. Portfolio of projects covering a similar scope as this invitation (Restricted to a minimum of 3 projects)	M	YES	NO	
Evidence of capability to manage and execute this bid and subsequent contract	M	YES	NO	
Evidence of who the bidder is i.e. company profile	M	YES	NO	
High level project plan demonstrating the bidder's proposed execution of the subsequent contract. This shall include enough information to make the scoring assessments as defined in the EVALUATION CRITERIA section starting on Page 11.	M	YES	NO	
Proof of Registration on the Government's Central Supplier Database	M	YES	NO	
B – BBEE Certificate (South African Companies) or, for companies that have less than R10 million turnover, a sworn affidavit or the certificate issued by the Companies and Intellectual Property Commission (CIPC) is required. A copy of the template for this affidavit is available on the Department of Trade and Industry website https://www.thedti.gov.za/gazette/Affidavit_EME.pdf	O	YES	NO	
Tax Confirmation Letter from Tax Authorities (Foreign Companies)	M	YES	NO	
Three (3) written references with contact details per relationship, type where applicable (i.e. maintenance, supply and commissioning, etc.), in the reference format specified in this. The form is for those customers for whom the bidder has completed work within the last twenty-four months and/or current work in progress. The customers are to complete the form on their own company letterhead.	M	YES	NO	
Reference 1 From:				
Reference 2 From:				
Reference 3 From:				
Any other requirements, if applicable	M	YES	NO	

RETURNABLE DOCUMENTS		Envelope 2			
Summary pricing in the SBD 3 format in this document	M	YES	NO		
Detail price sheets and supporting documents, including a breakdown of invoice totals with respect to each delivery.	M	YES	NO		

THE BIDDING PROCESS

This bid is evaluated through a three-stage process

Stage 1 – Compliance to Requirements including Mandatory as these are GO/NO GO gates

Bidders warrant that their proposal document has, as a minimum, the specified documents required for evaluating their proposals. The NRF provides the Returnable Document Checklist listing these including which documents are mandatory (GO/NO GO) to the bidders.

The NRF evaluates only procurement responses that are 100% acceptable in terms of the Returnable Document List. The NRF disqualifies bidders not compliant with this list for Stage 2.

Stage 2 – Evaluation of Bids against Specifications and Quality.

The NRF evaluates each bidder’s written response to the specifications issued in accordance to published evaluation criteria and the associated scoring set outlined in this bid invitation.

The NRF will, where circumstances justifies it, request an evaluation sessions such as interviews/presentations/pitching sessions/proof of functionality sessions with the bidders before concluding the evaluation stage.

Bidders making the minimum evaluation score will pass to stage 3.

Stage 3 – Price/Preference Evaluation

The NRF compares each bidder’s pricing proposal on an equal and fair comparison basis that is equitable to all bidders taking into account all aspects of the bids pricing requirements. The NRF ranks the qualifying bids on price and preference points claimed in the following manner:

Price - with the lowest priced Bid meeting the minimum specification as stipulated in the threshold to qualify for this stage receiving the highest price score as set out in the Preferential Procurement Policy 2011 Regulations;

Preference - preference points as claimed in the preference claim form (SBD6.1) supported by a valid BBBEE certification are added to the price ranking scores.

The NRF nominates the bidder with the highest combined score for the contract award subject to the bidder having supplied the relevant administrative documentation.

Bid Procedure Conditions:

Counter Conditions

The NRF draws bidders' attention that amendments to any of the Bid Conditions or setting of counter conditions by bidders will result in the invalidation of such bids.

Response Preparation Costs

The NRF is NOT liable for any costs incurred by a bidder in the process of responding to this Bid Invitation, including on-site presentations.

Cancellation Prior To Awarding

The NRF reserve the right to withdraw and cancel the Bid Invitation at any time prior to making an award.

Collusion, Fraud And Corruption

Any effort by Bidder/s to influence evaluation, comparisons, or award decisions in any manner will result in the rejection and disqualification of the bidder concerned.

Fronting

The NRF, in ensuring that bidders conduct themselves in an honest manner will, as part of the bid evaluation processes where applicable, conduct or initiate the necessary enquiries/investigations to determine the accuracy of the representation made in the bid documents. Should any of the fronting indicators as contained in the "Guidelines on complex Structures and Transactions and Fronting", issued by the Department of Trade and Industry, be established during such inquiry/investigation, the onus will be on the bidder to prove that fronting does not exist. Failure to do so within a period of 7 days from date of notification will invalidate the bid/contract and may also result in the restriction of the bidder to conduct business with the public sector for a period not exceeding 10 years, in addition to any other remedies the NRF may have against the bidder concerned.

Sub-contracting Direct

The NRF does not enter into any separate contracts with sub-contracted suppliers of its appointed bidders.

Information Provided In The Procurement Invitation

All information contained in this document is solely for the purposes of assisting bidders to prepare their Bids. The NRF prohibits bidders from using any of the information contained herein for other purpose than those stated in this document.

DISCLAIMERS

The NRF has produced this document in good faith. However, the NRF, its agents and its employees and associates, do not warrant its accuracy or completeness. To the extent that the NRF is permitted by law, the NRF will not be liable for any claim whatsoever and how so ever arising (including, without limitation, any claim in contract, negligence or otherwise) for any incorrect or misleading information contained in this document due to any misinterpretation of this document.

The NRF makes no representation, warranty, assurance, guarantee or endorsements to any provider/bidder concerning the document, whether with regard to its accuracy, completeness or otherwise and the NRF shall have no liability towards the responding service providers or any other party in connection therewith.

**THRESHOLD TO QUALIFY FOR PRICE/PREFERENCE
EVALUATION STAGE 3**

Bidders are not eligible for the next stage of evaluation, which is Price and Preference scoring, where they:

1. Score less than the minimum threshold of 50% on total score and/or
2. Have any criteria marked as “NO-GO” in GO/NO-GO evaluations.

EVALUATION CRITERIA FOR EVALUATING BIDDERS RESPONSES

	Selection Element	Weight				
1.	Bidder to supply evidence of a reputable supplier or manufacturer of the required uPVC and mPVC available to bidder (e.g. letter/company profile from manufacturer or supplier).	N/A	0 or NO GO Defined as not meeting minimum specification	1 or GO Defined as meeting the minimum specification	Reference to the Returnable document list	
					Reference to additional information supplied by the bidder	
2.	<u>Method</u> Evaluate that the geometry tolerances on fabricated parts can be met by the bidders' proposed fabrication technique. Note to evaluators: Use some or all of the following sources of supplied information as applicable: equipment datasheets, specifications, project plan, jig information, etc.	30%	NO-GO Does not meet the minimum specifications set, e.g. unpowered hand tools	10 Defined as meeting the minimum requirements with poor quality, e.g. un-metered power tools and no jigs	50 Defined as meeting the minimum requirements with good quality, e.g. metered power tools, or un-metered power tools with appropriate jigs	100 Defined as meeting the minimum requirements with good quality with added value, e.g. CNC machining

EVALUATION CRITERIA FOR EVALUATING BIDDERS RESPONSES

	Selection Element	Weight							
3.	<p><u>Storage</u></p> <p>Evaluate whether the proposed batch processing area is large enough to process and store the raw material and finished product quantities associated with at least one batch of items.</p> <p>Note to evaluators: Use some or all of the following sources of supplied information as applicable: company profile, reference letters received, bidders' description of resources available for the works specified, etc.</p>	30%	<p style="text-align: center;">NO-GO</p> <p>Defined as not meeting the minimum specifications set, e.g. no evidence of work space and storage capacity</p>	10	<p>Defined as dubious evidence of meeting the minimum specifications set, e.g. work space and storage space insufficient for at least one batch of items</p>	50	<p>Defined as meeting the minimum specifications set consistently, e.g. work space and storage capacity sufficient for at least one batch of items</p>	100	<p>Defined as exceeding the minimum specifications, e.g. work space and storage capacity exceeds that required for at least one batch of items</p>
4.	<p><u>Throughput</u></p> <p>Evaluate whether the proposed methods, including manpower available, are suitable for executing the works specified within the timeframes required, i.e. maximum batch delivery lead time of four (4) weeks.</p> <p>Note to evaluators: Use some or all of the following sources of supplied information as applicable: company profile, reference letters received, bidders' description of resources and equipment available for the works specified, etc.</p>	30%	<p style="text-align: center;">NO-GO</p> <p>Defined as not meeting the minimum specifications set, e.g. no evidence of manpower and tools available to do work.</p>	10	<p>Defined as dubious evidence of meeting the minimum specifications set, e.g. proposed team size and production method is not capable of meeting batch delivery lead time required</p>	50	<p>Defined as meeting the minimum specifications set consistently, e.g. proposed team size and production method is capable of meeting batch delivery lead time required</p>	100	<p>Defined as exceeding the minimum specifications, e.g. proposed team size and product method is capable of exceeding batch delivery lead time required</p>

EVALUATION CRITERIA FOR EVALUATING BIDDERS RESPONSES

	Selection Element	Weight							
5.	<p><u>Delivery</u></p> <p>Evaluate whether the proposed delivery method is suitable for transporting at least a full batch size as specified from the place of works to the HERA location at the SKA SA Losberg site.</p> <p>Note to evaluators: Use some or all of the following sources of supplied information as applicable: company profile, reference letters received, bidders' description of transport equipment or transport subcontractor to be used, etc.</p>	5%	<p style="text-align: center;">NO-GO</p> <p>Defined as not meeting the minimum specifications set, e.g. no description or evidence of delivery method</p>	10	<p>Defined as dubious evidence of meeting the minimum specifications set, e.g. delivery method proposed is not capable of transporting a full batch of items as specified to the Losberg site</p>	50	<p>Defined as meeting the minimum specifications set consistently, e.g. delivery method proposed is capable of delivering a full batch of items as specified to the Losberg site</p>	100	<p>Defined as exceeding the minimum specifications, e.g. delivery method proposed is capable of delivery more than a full batch of items as specified to the Losberg site</p>
6.	<p><u>Quality Assurance</u></p> <p>Evaluate whether the bidder has evidence of a formal quality management system (e.g. ISO 9001 certificate), or description and sufficient evidence of quality control processes employed to ensure that the items delivered are according to our desired specifications and that manufactured parts are within the allowable tolerances.</p>	15%	<p style="text-align: center;">NO-GO</p> <p>Defined as not meeting the minimum specifications set, e.g. no evidence of formal QMS or quality control processes employed.</p>	10	<p>Defined as dubious evidence of meeting the minimum specifications set, e.g. Minimal quality control processes employed; quality control processes not sufficient to ensure items meet specification consistently.</p>	50	<p>Defined as meeting the minimum specifications set consistently, e.g. Valid ISO 9001 certificate, or description and evidence of quality control processes to be used which are sufficient to ensure items meet specification consistently.</p>	100	<p>Defined as exceeding the minimum specifications, e.g. Description and evidence of quality control processes to be used which exceed that required to ensure items meet specification consistently.</p>

THE BIDDERS PARTICULARS

Name Of Bidder (As STATED on the Central Supplier Database registration report)	
Represented By	
Postal Address	
Telephone Number	
Cell Phone Number	
Facsimile Number	
E-Mail Address	
VAT Registration Number:	
COMPANY REGISTRATION NUMBER	

DESCRIBE PRINCIPAL BUSINESS ACTIVITIES:	
TYPE OF COMPANY/FIRM [Tick applicable box]	
Partnership/Joint Venture/Consortium	
Close Corporation	
(Pty) Limited	
One person business/sole proprietor	
Company	
Other	
COMPANY CLASSIFICATION [Tick applicable box and provide short description]	
Manufacturer:	
Supplier:	
Professional Service Provider:	
Research and Innovation:	
Construction:	
Logistics:	
Other:	
TOTAL NUMBER OF YEARS THE COMPANY/FIRM HAS BEEN IN BUSINESS	
TAX CLEARANCE CERTIFICATE	
Has an original and valid tax affairs in order letter or Central supplier database certificate with green tax status been submitted	Yes/No/NA

SUPPLIER NATIONAL TREASURY'S CENTRAL SUPPLIER DATABASE:			
Supplier Number	M	Unique Registration Reference Number (36 digit)	
PREFERENCE CLAIM			
Preference claim form been submitted for your preference points? (SBD 6.1)			Yes/No/NA
A B-BBEE status level verification certificate must support preference points claimed. Has this been submitted?			Yes/No/NA
Who was the B-BBEE certificate issued by [Tick applicable box]			
A verification agency accredited by the South African Accreditation System (SANAS);			Yes/No/NA
Affidavit confirming turnover and black ownership or Companies and Intellectual Property Commission Certificate confirming turnover and black ownership certified by the registered Commissioner of Oaths			Yes/No/NA
A Registered Auditor registered by IRBA			Yes/No/NA
Are you the accredited representative in South Africa for the goods/services/works offered?			
YES or NO If yes enclose proof in the annexure and summarized detail below			

CONTRACT PERIOD

The contract is for the supply and delivery of a fixed number of items. The contract lapses once the total required quantity of PVC parts has been received in good order. The contract period commences from the date that both parties sign the contract (SBD7 contract signature page)

SCOPE OF WORK

Product Requirements

With reference to Drawing Datapack: H0010-2000-001 Rev 1.

Table 1: Product Requirements

Req No.	HERA Part No.	Part Name	Supply Specification	Total Qty Req'd
[R1]	H1HU	Hub Spar	Fabricated uPVC part, as per Dwg. H1HU Rev B	1360
[R2]	H1HS	Hub Sleeve	Fabricated uPVC part, as per Dwg. H1HS Rev B	1360
[R3]	H1PV-P	Upright Support	Fabricated uPVC part, as per Dwg. H1PV-P Rev C	1360
[R4]	H1PV-01	uPVC 90deg	63mm dia. uPVC Fitting – Solvent Weld 90 deg. Elbow	1360
[R5]	H1RF-L	Long spar	Std. 63mm dia. Class 12 uPVC pipe, as per Dwg. H1RF-L Rev A	1360
[R6]	H1RF-S	Short spar	Fabricated uPVC part, as per Dwg. H1RF-S Rev A	1360
[R7]	H1RI	Intermediate spar	Std. 63mm dia. mPVC pipe, modified as per Dwg. H1RI Rev A. Note: mPVC, not uPVC	1360
[R8]	H1RC	Cross assembly	Fabricated uPVC assy, as per Dwg. H1RC Rev D	1360
[R9]	H1PS-F	Post Base Form	Fabricated uPVC part, as per Dwg. H1PS-F Rev A	560
[R10]		PVC adhesive	500ml can Alcolin PVC Weld adhesive	140

[R11] Drawings are provided for bid purposes/information only, and no manufacture shall take place against drawings not issued for that purpose.

Quality Assurance and Documentation

- [R12] The supplier shall have an inspection process in place for ensuring that the items which are delivered are according to the Product Requirements stated herein.
- [R13] At least 10% of each batch shall be formally inspected by the supplier prior to delivery.
- [R14] The supplier shall record details of inspections conducted, and deliver these inspection reports along with the batch.
- [R15] Any jigs manufactured in order to carry out the works described herein shall be inspected and accepted by SKA SA prior to commencement of manufacture.
- [R16] The supplier shall deliver the material certificate(s), batch certificate(s), or datasheet(s) as applicable of the PVC batch(es) that the items were manufactured from.

Batch Sizes and Delivery Schedule

The items specified in Table 1 shall be delivered over four nominally equal batches of volume specified in

[R17] Table 2.

[R18] The first batch shall be delivered on or before 1 July 2017.

Subsequent batches shall be delivered on request from the NRF, but no earlier than the dates in the dates in

[R19] Table 2 below, and no later than 4 weeks after receiving a written request from the NRF.

Quantity deviations per batch as allowed in

[R20] Table 2 shall not influence the total required item quantities.

Delivered quantity deviations in line with the acceptable quantity deviation allowed in

[R21] Table 2 shall be made up in the next delivered batch.

[R22] The final batch shall bring the total delivered item quantities over all batches to the total required quantities specified in Table 1.

Table 2: Batch Delivery Schedule

Batch No.	Item No.	Qty per batch	Acceptable deviation	Delivery Date
One	[R1] thru [R8]	340	± 10	1 July 2017
	[R9]	140	± 10	
	[R10]	35	± 5	
Two	[R1] thru [R8]	340	± 10	1 August 2017
	[R9]	140	± 10	
	[R10]	35	± 5	
Three	[R1] thru [R8]	340	± 10	1 September 2017
	[R9]	140	± 10	
	[R10]	35	± 5	
Four	[R1] thru [R8]	340	± 10	1 October 2017
	[R9]	140	± 10	
	[R10]	35	± 5	

Delivery Location

[R23] Each batch shall be delivered to the HERA location at the SKA SA Losberg site, located approximately 100 km north-west of the town of Carnarvon in the Northern Cape, and having GPS coordinates 30°43'15"S 21°25'40"E.

SPECIAL CONDITIONS FOR MANAGING THE CONTRACTUAL OBLIGATIONS

National Research Foundation

1. Contract Management

1.1. The NRF manages this contract fairly and objectively in accordance to the terms and conditions set out in this document.

2. Contract Manager

2.1. The NRF appoints a contract manager and notifies the other party in writing of

the contact details of the appointed contract manager.

3. Contract Communication

- 3.1. The NRF communicates all communications in writing. E-mail shall be considered suitable for this purpose.
- 3.2. The NRF maintains all contract documentation, correspondence, etc. in a defined contract file open for inspection.
- 3.3. The NRF states the contract number with secondary reference numbers i.e. purchase numbers on all communication, documentation such as purchase orders issued, etc. The NRF will consider any communication without the contract number on as not being legal communication between the parties and not enacted on by either party as a protection against fraud.

4. Communicating “As and When” in terms of the specific contract clauses

- 4.1. Where prices and/or availability need to be confirmed, a request for an updated detail quotation/information is issued;
- 4.2. Where specific procurement items as specified in the contract are required, the NRF issues a purchase order stating the contract number for the requirement.
- 4.3. Such purchase order has the following detail (where this is not provided, the purchase order is not a valid communication in terms of this contract):
 - 4.3.1. Purchase Order Number
 - 4.3.2. Contract Number
 - 4.3.3. Quantity
 - 4.3.4. Description of the required procurement. Where detailed, reference must be made to the relevant technical document attached;
 - 4.3.5. Catalogue number if applicable;
 - 4.3.6. Unit price per this contract;
 - 4.3.7. Delivery Date;
 - 4.3.8. Business unit code; and
- 4.4. The specific delivery site.

5. Performance Management

- 5.1. The NRF measures performance throughout the contract life in accordance with the service levels set in this document.
- 5.2. The NRF has regular performance reviews with the contractor.
- 5.3. Where severe non-performance occurs the NRF will terminate the contract earlier in consultation with the contractor.

SERVICE PERFORMANCE LEVELS (MANDATORY)

Service being Measured	Measurement	Minimum level
Batch delivery volume	Verified delivery documentation received by the NRF, and receiving inspections	As per req’s 0, 0, [R22] in this document
Batch delivery according to schedule	Verified delivery documentation received by the NRF	As per req’s [R18] and 0 in this document

Quality of manufactured parts	Inspection of delivered items within five (5) working days of delivery; inspection reports received from supplier	As per specifications in [R1] through [R10] in this document.
-------------------------------	---	---

CONTRACTED BIDDER

1. Managing the Contract

1.1. The contracted party manages this contract fairly and objectively in accordance to the terms and conditions set out in this document.

2. Contract Manager

2.1. The contracted party appoints a contract manager and notifies the NRF in writing of the name and contact details of the appointed contract manager.

3. Communication

3.1. The contracted party communicates in writing and through email.

3.2. The contracted party always states the contract number on communication, documentation such as correspondence, purchase orders issued, etc. and will not act upon any communication without the contract number or must verify such communication with the NRF prior to acting upon it.

4. Managing the execution of this bid/contract

4.1. Where different stages apply, the contracted party communicates in writing the commencement of the stage to the NRF.

5. Occupational Health and Safety Requirements

5.1. The contracted supplier, once the SBD7 is signed, is responsible for itself, its employees, and those people affected by its operations in terms of the Occupational Health and Safety Act the regulations promulgated in terms thereof (OHS Act No 85 of 1993 and its Regulations).

5.2. The contracted supplier performs all work and uses equipment on site complying with the provisions of the Occupational Health and Safety Act.

5.3. To this end, the contracted supplier shall make available to NRF the valid letter of good conduct and shall ensure that its validity does not expire while executing this bid.

5.4. The contracted supplier furnishes, upon signing of the SBD7, its registration number with the office of the Compensation Commissioner.

5.5. The NRF undertakes to ensure that the contracted supplier in his capacity for the execution of this contract accepts liability to comply with the provisions of the said Act and the regulations promulgated in terms thereof.

PRICING DETAIL

SBD 3 - Pricing Schedule for the Duration of the Contract

(SBD 3.1 - Firm Unit Pricing)

NOTE

Price quoted is fully inclusive of all costs including delivery to the specified NRF Business Unit geographical address and includes value- added tax, pay as you earn, income tax, unemployment insurance fund contributions, and skills development levies.
In cases where different delivery points influence the pricing, a separate pricing schedule must be submitted for each delivery point
Detailed information i.e. costed bill of quantities is optional and can be provided as an annexure to the details provided
The NRF accepts no changes, extensions, or additional ad hoc costs to the pricing conditions of the contract once both parties have signed the contract.
Pricing is subject to the addition of Preference Points as stipulated below - Standard Bidding Document 6.1 Preference claim form.

BID PRICE IN RSA RAND (ALL APPLICABLE TAXES INCLUDED)

(WHERE FOREIGN EXCHANGE APPLIES, AND THE BIDDERS USE DIFFERENT EXCHANGE RATES, A UNIFORM RATE WILL BE USED BY THE NRF TO ADJUST THE QUOTED PRICES TO ALLOW FOR FAIR COMPARISON)

<u>NO</u>	<u>QTY</u>	<u>DESCRIPTION</u>	<u>UNIT OF MEASURE</u> (e.g. per item, per kg)	<u>UNIT PRICE (VAT INCL.)</u>
		BATCH ONE		
1	340	Hub Spar as per [R1]		
2	340	Hub Sleeve as per [R2]		
3	340	Vertical Support as per [R3]		
4	340	uPVC 90deg as per [R4]		
5	340	Long spar as per [R5]		
6	340	Short spar as per [R6]		
7	340	Intermediate spar as per [R7]		
8	340	Cross assembly as per [R8]		
9	140	Post Base Form as per [R9]		
10	35	PVC adhesive as per [R10]		

11	1	Delivery to SKA SA Losberg site		
Subtotal Cost is determined by multiplying quantity by unit price				
SUBTOTAL BATCH ONE (VAT INCL.)		R		

<u>NO</u>	<u>QTY</u>	<u>DESCRIPTION</u>	<u>UNIT OF MEASURE</u> (e.g. per item, per kg)	<u>UNIT PRICE (VAT INCL.)</u>
		BATCH TWO		
12	340	Hub Spar as per [R1]		
13	340	Hub Sleeve as per [R2]		
14	340	Vertical Support as per [R3]		
15	340	uPVC 90deg as per [R4]		
16	340	Long spar as per [R5]		
17	340	Short spar as per [R6]		
18	340	Intermediate spar as per [R7]		
19	340	Cross assembly as per [R8]		
20	140	Post Base Form as per [R9]		
21	35	PVC adhesive as per [R10]		
22	1	Delivery to SKA SA Losberg site		
Subtotal Cost is determined by multiplying quantity by unit price				
SUBTOTAL BATCH TWO (VAT INCL.)			R	
<u>NO</u>	<u>QTY</u>	<u>DESCRIPTION</u>	<u>UNIT OF MEASURE</u> (e.g. per item, per kg)	<u>UNIT PRICE (VAT INCL.)</u>
		BATCH THREE		
23	340	Hub Spar as per [R1]		
24	340	Hub Sleeve as per [R2]		
25	340	Vertical Support as per [R3]		
26	340	uPVC 90deg as per [R4]		
27	340	Long spar as per [R5]		

28	340	Short spar as per [R6]		
29	340	Intermediate spar as per [R7]		
30	340	Cross assembly as per [R8]		
31	140	Post Base Form as per [R9]		
32	35	PVC adhesive as per [R10]		
33	1	Delivery to SKA SA Losberg site		
Subtotal Cost is determined by multiplying quantity by unit price				
SUBTOTAL BATCH THREE (VAT INCL.)			R	
<u>NO</u>	<u>QTY</u>	<u>DESCRIPTION</u>	<u>UNIT OF MEASURE</u> (e.g. per item, per kg)	<u>UNIT PRICE (VAT INCL.)</u>
		BATCH FOUR		
34	340	Hub Spar as per [R1]		
35	340	Hub Sleeve as per [R2]		
36	340	Vertical Support as per [R3]		
37	340	uPVC 90deg as per [R4]		
38	340	Long spar as per [R5]		
39	340	Short spar as per [R6]		
40	340	Intermediate spar as per [R7]		
41	340	Cross assembly as per [R8]		
42	140	Post Base Form as per [R9]		
43	35	PVC adhesive as per [R10]		
44	1	Delivery to SKA SA Losberg site		
Subtotal Cost is determined by multiplying quantity by unit price				

SUBTOTAL BATCH FOUR (VAT INCL.)		R		
<u>NO</u>	<u>QTY</u>	<u>DESCRIPTION</u>	<u>UNIT OF MEASURE</u> (e.g. per item, per kg)	<u>UNIT PRICE (VAT INCL.)</u>
		OTHER		
45		Custom jigs, if applicable		
46				
47				
Subtotal Cost is determined by multiplying quantity by unit price				
SUBTOTAL OTHER (VAT INCL.)		R		
Total Cost is determined by adding up all Subtotal Costs				
TOTAL COSTED VALUE OF ABOVE (VAT INCL.)		R		
Delivery Administration				
	Required by Business Unit:	SKA SA		
	At delivery site:	SKA SA Losberg Site. Delivery date and time to be pre-arranged with SKA SA at least two days prior to delivery date.		
	Period required for delivery upon placement of delivery instruction:	4 weeks		
	Delivery	Firm		
	Delivery basis	Full cost to delivery site		

PREFERENCE POINTS CLAIMED (SBD 6.1)

NB: BEFORE COMPLETING THIS FORM, BIDDERS MUST STUDY THE GENERAL CONDITIONS, DEFINITIONS, AND DIRECTIVES APPLICABLE IN RESPECT OF B-BBEE, AS PRESCRIBED IN THE PREFERENTIAL PROCUREMENT REGULATIONS, 2011.

In terms of Regulation 5 (2) and 6 (2) of the Preferential Procurement Regulations, preference points are awarded to a Bidder for attaining the B-BBEE status level of contribution in accordance with the table below:

The following preference point systems are applicable to all bids:

the 80/20 system for requirements with a Rand value of up to R50 000 000 (all applicable taxes included); and

the 90/10 system for requirements with a Rand value above R50 000 000 (all applicable taxes included).

The value of this bid is estimated to **not** exceed R50 000 000 (all applicable taxes included) and therefore the preference point system below shall be applicable.

THE MAXIMUM POINTS FOR THIS BID ARE ALLOCATED AS FOLLOWS:

POINTS

PRICE

80

B-BBEE STATUS LEVEL OF CONTRIBUTION

20

Total points for Price and B-BBEE must not exceed

100

Preference Points for this bid is awarded in accordance with the table below:

BBEE Status Level of Contributor per B-BBEE Certificate	Preference Points Claimed
1	20
2	18
3	16
4	12
5	8

6	6
7	4
8	2
Non-Compliant	0
<p>Failure on the part of a bidder to submit a B-BBEE Verification Certificate from a Verification Agency accredited by the South African Accreditation System (SANAS), or a Registered Auditor approved by the Independent Regulatory Board of Auditors (IRBA) or a sworn affidavit confirming annual turnover and level of black ownership in case of an EME and QSE together with the bid, will be interpreted to mean that preference points for B-BBEE status level of contribution are not claimed.</p>	
<p>The purchaser reserves the right to require, either before adjudicating the bid or at any time subsequently, of the bidder to substantiate any claim to preferences in any manner required.</p>	
<p>A bidder who qualifies as an EME in terms of the B-BBEE Act must submit a valid BBBEE certificate (South African Companies) if available or a sworn affidavit (SAPS) confirming Annual Total Revenue and Level of Black Ownership or a Companies and Intellectual Property Commission (CIPC) certificate stipulating Annual Total Revenue and Level of Black Ownership. A copy of the template for this affidavit is available on the Department of Trade and Industry website https://www.thedti.gov.za/gazette/Affidavit_EME.pdf</p> <p>A Bidder other than EME or QSE must submit their original and valid B-BBEE status level verification certificate or a certified copy thereof, substantiating their B-BBEE rating issued by a Registered Auditor approved by IRBA or a Verification Agency accredited by SANAS.</p> <p>A trust, consortium or joint venture, will qualify for points for their B-BBEE status level as a legal entity, if the entity submits their B-BBEE status level certificate.</p> <p>A trust, consortium, or joint venture will qualify for points for their B-BBEE status level as an unincorporated entity, if the entity submits their consolidated B-BBEE scorecard as if they were a group structure and that such a consolidated B-BBEE scorecard is prepared for every separate bid.</p> <p>Tertiary Institutions and Public Entities will be required to submit their B-BBEE status level certificates in terms of the specialized scorecard contained in the B-BBEE Codes of Good Practice.</p> <p>A person will not be awarded points for B-BBEE status level if it is indicated in the bid documents that such a bidder intends sub-contracting more than 25% of the value of the contract to any other enterprise that does not qualify for at least the points that such a bidder qualifies for, unless the intended sub-contractor is an EME that has the capability and ability to execute the sub-contract.</p>	

<p>A person awarded a contract may not sub-contract more than 25% of the value of the contract to any other enterprise that does not have an equal or higher B-BBEE status level than the person concerned, unless the contract is sub-contracted to an EME that has the capability and ability to execute the sub-contract.</p>	
<p>BID DECLARATION: B-BBEE STATUS LEVEL OF CONTRIBUTION CLAIMED IN TERMS OF THE ABOVE TABLE:</p>	
B-BBEE Status level claimed	
Preference Points claimed	
<p>BID DECLARATION: SUB-CONTRACTING</p>	
Will any portion of the contract be sub-contracted?	YES / NO
<p>If Yes, indicate:</p>	
What percentage of the contract will be subcontracted?	
Names of the sub-contractor	
The B-BBEE status level of the sub-contractor	
Whether the sub-contractor is an EME?	YES / NO
<p>I/we, the undersigned, who is/are duly authorized to do on behalf of the company/firm, certify that the points claimed, based on the B-BBEE status level of contribution of the foregoing certificate, qualifies the company/ firm for the preference(s) shown and I/we acknowledge that:</p> <p>The information furnished is true and correct;</p> <p>The preference points claimed are in accordance with the Preferential Procurement Policy Framework Act and its Regulations;</p> <p>In the event of a contract being awarded as a result of points claimed as shown above, the contractor may be required to furnish documentary proof to the satisfaction of the purchaser that the claims are correct;</p> <p>If the B-BBEE status level of contribution has been claimed or obtained on a fraudulent basis or any of the conditions of contract have not been fulfilled, the purchaser may, in addition to any other remedy it may have –</p>	

	<p>Disqualify the Bidder from the bidding process;</p> <p>Recover costs, losses or damages it has incurred or suffered as a result of that Bidder's conduct;</p> <p>Cancel the contract and claim any damages which it has suffered as a result of having to make less favourable arrangements due to such cancellation;</p> <p>Restrict the Bidder or contractor, its shareholders and directors, or only the shareholders and directors who acted on a fraudulent basis, from obtaining business from any NRF for a period not exceeding ten (10) years, after the audi alteram partem (hear the other side) rule has been applied; and forward the matter for criminal prosecution; and</p> <p>Forward the matter for criminal prosecution.</p>
--	--

DUE DILIGENCE REQUIREMENTS

	<p>Written References from South African Revenue Services for either companies not registered in South Africa or do not have a local registered subsidiary</p>
	<p>Bidders are required to provide evidence of good standing with their tax office (overseas and local).</p> <p>Where the bidder is a South African citizen and meets the threshold for tax registration, the Central Supplier Database registration provides the verification of the bidder's tax status. Foreign bidders, where they have a South African legal registered entity, must comply with this requirement.</p> <p>Where the foreign bidders do not have a South African legal entity, they are exempt from this requirement. For due diligence, where their country of residence has the same requirement of tax status, a copy of that certificate should be provided.</p>
	<p>SBD 9: CERTIFICATE OF INDEPENDENT BID DETERMINATION</p>
	<p>I, the undersigned, in submitting this Bid in response to the invitation for the Bid made by the NRF, do hereby make the following statements that I certify to be true and complete in every respect:</p>
	<p>I have read and I understand the contents of this Certificate;</p>
	<p>I understand that the Bid will be disqualified if this Certificate is found not to be true and complete in every respect;</p>

<p>I am authorised by the Bidder to sign this Certificate, and to submit the Bid, on behalf of the Bidder;</p>	
<p>Each person whose signature appears on the Bid has been authorised by the Bidder to determine the terms of, and to sign, the Bid on behalf of the Bidder;</p>	
<p>For the purposes of this Certificate and the accompanying Bid, I understand that the word “competitor” shall include any individual or organisation, other than the Bidder, whether or not affiliated with the Bidder, who:</p> <ul style="list-style-type: none"> a) Has been requested to submit a Bid in response to this Bid invitation; b) Could potentially submit a Bid in response to this Bid invitation, based on their qualifications, abilities or experience; and c) Provides the same goods and services as the Bidder and/or is in the same line of business as the Bidder 	
<p>The Bidder has arrived at the accompanying Bid independently from, and without consultation, communication, agreement, or arrangement with any competitor. However, communication between partners in a joint venture or consortium ³ will not be construed as collusive bidding.</p>	
<p>In particular, without limiting the generality of paragraphs above, there has been no consultation, communication, agreement or arrangement with any competitor regarding:</p> <ul style="list-style-type: none"> a) Prices; b) Geographical area where product or service will be rendered (market allocation); c) Methods, factors or formulas used to calculate prices; d) The intention or decision to submit or not to submit, a Bid; e) The submission of a Bid which does not meet the specifications and conditions of the Bid; or f) Bidding with the intention not to win the Bid. 	
<p>In addition, there have been no consultations, communications, agreements, or arrangements with any competitor regarding the quality, quantity, specifications and conditions or delivery particulars of the products or services to which this Bid invitation relates.</p>	
<p>The terms of this Bid have not been, and will not be, disclosed by the Bidder, directly or indirectly, to any competitor, prior to the date and time of the official Bid opening or of the awarding the bid or to the signing of the contract.</p>	

<p>I am aware that, in addition and without prejudice to any other remedy provided to combat any restrictive practices related to Bids and contracts, Bids that are suspicious will be reported to the Competition Commission for investigation and possible imposition of administrative penalties in terms of Section 59 of the Competition Act No 89 of 1998 and or may be reported to the National Prosecuting Authority (NPA) for criminal investigation and or may be restricted from conducting business with the public sector for a period not exceeding ten (10) years in terms of the Prevention and Combating of Corrupt Activities Act No 12 of 2004 or any other applicable legislation</p>	
<p>³ Joint venture or Consortium means an association of persons for the purpose of combining their expertise, property, capital, efforts, skill and knowledge in an activity for the execution of</p>	
<p>SBD 8 - DECLARATION OF BIDDER'S PAST SCM PRACTICES</p>	
<p>Is the Bidder or any of its directors listed on the National Treasury's Database of Restricted Suppliers as companies or persons prohibited from doing business with the public sector? If Yes, furnish particulars as an attached schedule:</p>	<p>YES / NO</p>
<p>Is the Bidder or any of its directors listed on the Register for Tender Defaulters in terms of Section 29 of the Prevention and Combating of Corrupt Activities Act (No 12 of 2004)? If Yes, furnish particulars as an attached schedule:</p>	<p>YES / NO</p>
<p>Was the Bidder or any of its directors convicted by a court of law (including a court outside of the Republic of South Africa) for fraud or corruption during the past five years? If Yes, furnish particulars as an attached schedule:</p>	<p>YES / NO</p>
<p>Was any contract between the Bidder and any NRF terminated during the past five years because of failure to perform on or comply with the contract? If Yes, furnish particulars as an attached schedule:</p>	<p>YES / NO</p>
<p>The Database of Restricted Suppliers and Register for Tender Defaulters resides on the National Treasury's website (www.treasury.gov.za) and can be accessed by clicking on its link at the bottom of the home page.</p>	
<p>SBD 4 - DECLARATION OF INTEREST WITH GOVERNMENT</p>	
<p>Any legal person, including persons employed by the STATE ¹, or persons having a kinship with persons employed by the STATE, including a blood relationship, may make an offer or offers in terms of this invitation to Bid (includes an advertised competitive Bid, a limited Bid,</p>	

a proposal or written price quotation). In view of possible allegations of favouritism, should the resulting Bid, or part thereof, be awarded to persons employed by the STATE, or to persons connected with or related to them, it is required that the Bidder or his/her authorised representative, declare his/her position in relation to the evaluating/adjudicating authority where:

The Bidder is employed by the STATE ; and/or

The legal person on whose behalf the Bidding Document is signed, has a relationship with persons/s person who is/are involved in the evaluation and or adjudication of the Bid(s), or where it is known that such a relationship exists between the person or persons for or on whose behalf the declarant acts and persons who are involved with the evaluation and/or adjudication of the Bid.

In order to give effect to the above, the following questionnaire must be completed and submitted with this Bid:

Full Name of Bidder or his/her representative

Identity Number:

Position occupied in the Company (director, trustee, shareholder, member):

Registration number of company, enterprise, close corporation, partnership agreement

Tax Reference Number:

VAT Registration Number:

The names of all directors/trustees/shareholders/members, their individual identity numbers, tax reference numbers and, if applicable, employee/PERSAL numbers must be indicated in a separate schedule including the following questions:

Schedule attached with the above details for all directors/members/shareholders

Are you or any person connected with the Bidder presently employed by the STATE? If so, furnish the following particulars in an attached schedule

YES / NO

Name of person/ director/ trustee/ shareholder/member:

Name of STATE institution at which you or the person connected to the Bidder is employed	
Position occupied in the STATE institution	
Any other particulars:	
If you are presently employed by the STATE, did you obtain the appropriate authority to undertake remunerative work outside employment in the public sector?	YES / NO
If Yes, did you attach proof of such authority to the Bid document?	
If No, furnish reasons for non-submission of such proof as an attached schedule	
(Note: Failure to submit proof of such authority, where applicable, may result in the disqualification of the Bid.)	
Did you or your spouse or any of the company's directors/ trustees/ shareholders/ members or their spouses conduct business with the STATE in the previous twelve months?	YES / NO
If so, furnish particulars as an attached schedule:	
Do you, or any person connected with the Bidder, have any relationship (family, friend, other) with a person employed by the STATE and who may be involved with the evaluation and or adjudication of this Bid?	YES / NO
If so, furnish particulars as an attached schedule.	
Do you or any of the directors/ trustees/ shareholders/ members of the company have any interest in any other related companies whether or not they are bidding for this contract?	YES / NO
If so, furnish particulars as an attached schedule.	

GENERAL CONDITIONS OF CONTRACT (With amendments to these as separate SPECIAL CONDITIONS)

In this document words in the singular also mean in the plural and vice versa, words in the masculine mean in the feminine and neuter, and words such as “will/should/shall” mean “must”.

The NRF cannot amend the National Treasury’s General Conditions of Contract (GCC). The NRF appends Special Conditions of Contract (SCC) providing specific information relevant to a GCC clause directly below the specific GCC clause and where the NRF requires a SCC that is not part of the GCC, the NRF appends the SCC clause after all the GCC clauses. No clause in this document shall be in conflict with another clause.

GCC1	1. Definitions - The following terms shall be interpreted as indicated:
	<ul style="list-style-type: none"> 1.1. “Closing time” means the date and hour specified in the bidding documents for the receipt of bids. 1.2. “Contract” means the written agreement entered into between the purchaser and the supplier, as recorded in the contract form signed by the parties, including all attachments and appendices thereto and all documents incorporated by reference therein. 1.3. “Contract price” means the price payable to the supplier under the contract for the full and proper performance of his contractual obligations. 1.4. “Corrupt practice” means the offering, giving, receiving, or soliciting of anything of value to influence the action of a public official in the procurement process or in contract execution. 1.5. "Countervailing duties" are imposed in cases where an enterprise abroad is subsidized by its government and encouraged to market its products internationally. 1.6. “Country of origin” means the place where the goods were mined, grown, or produced or from which the services are supplied. Goods are produced when, through manufacturing, processing or substantial and major assembly of components, a commercially recognized new product results that is substantially different in basic characteristics or in purpose or utility from its components. 1.7. “Day” means calendar day. 1.8. “Delivery” means delivery in compliance of the conditions of the contract or order. 1.9. “Delivery ex stock” means immediate delivery directly from stock actually on hand. 1.10. “Delivery into consignees store or to his site” means delivered and unloaded in the specified store or depot or on the specified site in compliance with the conditions of the contract or order, the supplier bearing all risks and charges involved until the supplies are so delivered and a valid receipt is obtained.

	<p>1.11. "Dumping" occurs when a private enterprise abroad market its goods on own initiative in the RSA at lower prices than that of the country of origin and which have the potential to harm the local industries in the RSA.</p> <p>1.12. "Force majeure" means an event beyond the control of the supplier and not involving the supplier's fault or negligence and not foreseeable. Such events may include, but is not restricted to, acts of the purchaser in its sovereign capacity, wars, or revolutions, fires, floods, epidemics, quarantine restrictions and freight embargoes.</p> <p>1.13. "Fraudulent practice" means a misrepresentation of facts in order to influence a procurement process or the execution of a contract to the detriment of any bidder, and includes collusive practice among bidders (prior to or after bid submission) designed to establish bid prices at artificial non-competitive levels and to deprive the bidder of the benefits of free and open competition.</p> <p>1.14. "GCC" mean the General Conditions of Contract.</p> <p>1.15. "Goods" means all of the equipment, machinery, and/or other materials that the supplier is required to supply to the purchaser under the contract.</p> <p>1.16. "Imported content" means that portion of the bidding price represented by the cost of components, parts or materials which have been or are still to be imported (whether by the supplier or his subcontractors) and which costs are inclusive of the costs abroad, plus freight and other direct importation costs such as landing costs, dock dues, import duty, sales duty or other similar tax or duty at the South African place of entry as well as transportation and handling charges to the factory in the Republic where the supplies covered by the bid will be manufactured.</p> <p>1.17. "Local content" means that portion of the bidding price, which is not included in the imported content provided that local manufacture does take place.</p> <p>1.18. "Manufacture" means the production of products in a factory using labour, materials, components, and machinery and includes other related value-adding activities.</p> <p>1.19. "Order" means an official written order issued for the supply of goods or works or the rendering of a service.</p> <p>1.20. "Project site," where applicable, means the place indicated in bidding documents.</p> <p>1.21. "Purchaser" means the organization purchasing the goods.</p> <p>1.22. "Republic" means the Republic of South Africa.</p> <p>1.23. "SCC" means the Special Conditions of Contract.</p> <p>1.24. "Services" means those functional services ancillary to the supply of the goods, such as transportation and any other incidental services, such as installation, commissioning, provision of technical assistance, training, catering, gardening, security, maintenance and other such obligations of the supplier covered under the contract.</p> <p>1.25. "Written" or "in writing" means handwritten in ink or any form of electronic or mechanical writing.</p>
--	---

GCC2	2. Application
	<p>2.1. These general conditions are applicable to all bids, contracts and orders including bids for functional and professional services, sales, hiring, letting and the granting or acquiring of rights, but excluding immovable property, unless otherwise indicated in the bidding documents.</p> <p>2.2. Where applicable, special conditions of contract are also laid down to, cover specific supplies, services or works.</p> <p>2.3. Where such special conditions of contract are in conflict with these general conditions, the special conditions shall apply.</p>
GCC3	3. General
	<p>3.1. Unless otherwise indicated in the bidding documents, the purchaser shall not be liable for any expense incurred in the preparation and submission of a bid. Where applicable a non-refundable fee for documents may be charged.</p> <p>3.2. With certain exceptions (National Treasury's eTender website), invitations to bid are only published in the Government Tender Bulletin. The Government Tender Bulletin may be obtained directly from the Government Printer, Private Bag X85, Pretoria 0001, or accessed electronically from www.treasury.gov.za</p>
GCC4	4. Standards
	<p>4.1. The goods supplied shall conform to the standards mentioned in the bidding documents and specifications.</p>
GCC5	5. Use of contract documents and information
	<p>5.1. The supplier shall not, without the purchaser's prior written consent, disclose the contract, or any provision thereof, or any specification, plan, drawing, pattern, sample, or information furnished by or on behalf of the purchaser in connection therewith, to any person other than a person employed by the supplier in the performance of the contract. Disclosure to any such employed person shall be made in confidence and shall extend only as far as may be necessary for purposes of such performance.</p> <p>5.2. The supplier shall not, without the purchaser's prior written consent, make use of any document or information mentioned in GCC clause 5.1 except for purposes of performing the contract.</p> <p>5.3. Any document, other than the contract itself mentioned in GCC clause 5.1 shall remain the property of the purchaser and shall be returned (all copies) to the purchaser on completion of the supplier's performance under the contract if so required by the purchaser.</p> <p>5.4. The supplier shall permit the purchaser to inspect the supplier's records relating to the performance of the supplier and to have them audited by</p>

	auditors appointed by the purchaser, if so required by the purchaser.
GCC6	6. Patent rights
	6.1. The supplier shall indemnify the purchaser against all third-party claims of infringement of patent, trademark, or industrial design rights arising from use of the goods or any part thereof by the purchaser.
GCC7	7. Performance security
	<p>7.1. Within thirty days (30) of receipt of the notification of contract award, the successful bidder shall furnish to the purchaser the performance security of the amount specified in SCC.</p> <p>7.2. The proceeds of the performance security shall be payable to the purchaser as compensation for any loss resulting from the supplier's failure to complete his obligations under the contract.</p> <p>7.3. The performance security shall be denominated in the currency of the contract, or in a freely convertible currency acceptable to the purchaser and shall be in one of the following forms:</p> <p>7.3.1. bank guarantee or an irrevocable letter of credit issued by a reputable bank located in the purchaser's country or abroad, acceptable to the purchaser, in the form provided in the bidding documents or another form acceptable to the purchaser; or</p> <p>7.3.2. a cashier's or certified cheque</p> <p>7.4. The performance security will be discharged by the purchaser and returned to the supplier not later than thirty (30) days following the date of completion of the supplier's performance obligations under the contract, including any warranty obligations, unless otherwise specified in SCC.</p>
GCC7 SCC 1	GCC Not applicable to this contract
GCC8	8. Inspections, tests and analyses
	<p>8.1. All pre-bidding testing will be for the account of the bidder.</p> <p>8.2. If it is a bid condition that supplies to be produced or services to be rendered should at any stage during production or execution or on completion be subject to inspection, the premises of the bidder or contractor shall be open, at all reasonable hours, for inspection by a representative of the Department or an organization acting on behalf of the Department.</p> <p>8.3. If there are no inspection requirements indicated in the bidding documents and no mention is made in the contract, but during the contract period, it is decided that inspections shall be carried out, the purchaser shall itself make the necessary arrangements, including payment arrangements with the testing authority concerned.</p> <p>8.4. If the inspections, tests and analyses referred to in clauses 8.2 and 8.3</p>

	<p>show the supplies to be in accordance with the contract requirements, the cost of the inspections, tests and analyses shall be defrayed by the purchaser.</p> <p>8.5. Where the supplies or services referred to in clauses 8.2 and 8.3 do not comply with the contract requirements, irrespective of whether such supplies or services are accepted or not, the cost in connection with these inspections, tests, or analyses shall be defrayed by the supplier.</p> <p>8.6. Supplies and services which are referred to in clauses 8.2 and 8.3 and which do not comply with the contract requirements may be rejected.</p> <p>8.7. Any contract supplies may on or after delivery be inspected, tested or analysed and may be rejected if found not to comply with the requirements of the contract. Such rejected supplies shall be held at the cost and risk of the supplier who shall, when called upon, remove them immediately at his own cost and forthwith substitute them with supplies, which do comply with the requirements of the contract. Failing such removal the rejected supplies shall be returned at the suppliers cost and risk. Should the supplier fail to provide the substitute supplies forthwith, the purchaser may, without giving the supplier further opportunity to substitute the rejected supplies, purchase such supplies as may be necessary at the expense of the supplier.</p> <p>8.8. The provisions of clauses 8.4 to 8.7 shall not prejudice the right of the purchaser to cancel the contract on account of a breach of the conditions thereof, or to act in terms of Clause 23 of GCC.</p>
<p>GCC8 SCC 1</p>	<p>The NRF will conduct receiving inspections against the specifications in this document. If no communication has been received after five (5) working days from verified delivery, the supplier may assume acceptance of the delivery by the NRF for invoicing purposes only. This does not negate GCC 15.</p>
<p>GCC9</p>	<p>9. Packing</p>
	<p>9.1. The supplier shall provide such packing of the goods as is required to prevent their damage or deterioration during transit to their final destination, as indicated in the contract. The packing shall be sufficient to withstand, without limitation, rough handling during transit and exposure to extreme temperatures, salt and precipitation during transit, and open storage. Packing, case size and weights shall take into consideration, where appropriate, the remoteness of the goods' final destination and the absence of heavy handling facilities at all points in transit.</p> <p>9.2. The packing, marking, and documentation within and outside the packages shall comply strictly with such special requirements as shall be expressly provided for in the contract, including additional requirements, if any, specified in SCC, and in any subsequent instructions ordered by the purchaser.</p>

GCC10	10. Delivery and Documentation
	<p>10.1. Delivery of the goods shall be made by the supplier in accordance with the terms specified in the contract. The details of shipping and/or other documents to be furnished by the supplier are specified in SCC.</p> <p>10.2. Documents to be submitted by the supplier are specified in SCC.</p>
GCC10 SCC 1	The supplier shall provide a signed delivery note indicating the official order against which the delivery or service is being made, the actual number of items delivered, date of delivery, and company or individual that effected the delivery. To be signed 'delivered' by the supplier's representative and signed 'received' by the NRF's representative.
GCC10 SCC 2	Deliveries not complying with this are not accepted, at the Contractor's expense.
GCC10 SCC 3	The NRF is under no obligation to accept any quantity that is in excess of the ordered quantity.
GCC10 SCC 4	NRF representative verifies both delivery and performance prior to signing a certificate evidencing such performance, or otherwise communicating acceptance in writing.
GCC10 SCC 5	The Contractor must ensure such signed approved verification accompanies the subsequent supplier invoice.
GCC11	11. Insurance
	<p>11.1. The goods supplied under the contract shall be fully insured in a freely convertible currency against loss or damage incidental to manufacture or acquisition, transportation, storage and delivery in the manner specified in the SCC.</p>
GCC11 SCC 1	The supplier shall ensure that public liability insurance covering transport and delivery of the items specified is in place for a minimum value of R 5 000 000.00.
GCC12	12. Transportation
	<p>12.1. Should a price other than an all-inclusive delivered price be required, this shall be specified in the SCC.</p>
GCC13	13. Incidental services
	<p>13.1. The supplier may be required to provide any or all of the following services, including additional services, if any, specified in SCC:</p> <p>13.1.1. performance or supervision of on-site assembly and/or commissioning of the supplied goods;</p>

	<p>13.1.2. furnishing of tools required for assembly and/or maintenance of the supplied goods;</p> <p>13.1.3. furnishing of a detailed operations and maintenance manual for each appropriate unit of the supplied goods;</p> <p>13.1.4. performance or supervision or maintenance and/or repair of the supplied goods, for a period of time agreed by the parties, provided that this service shall not relieve the supplier of any warranty obligations under this contract; and</p> <p>13.1.5. training of the purchaser's personnel, at the supplier's plant and/or on-site, in assembly, start-up, operation, maintenance, and/or repair of the supplied goods.</p> <p>13.2. Prices charged by the supplier for incidental services, if not included in the contract price for the goods, shall be agreed upon in advance by the parties and shall not exceed the prevailing rates charged to other parties by the supplier for similar services.</p>
GCC14	14. Spare parts
	<p>14.1. As specified in SCC, the supplier may be required to provide any or all of the following materials, notifications, and information pertaining to spare parts manufactured or distributed by the supplier:</p> <p>14.1.1. such spare parts as the purchaser may elect to purchase from the supplier, provided that this election shall not relieve the supplier of any warranty obligations under the contract; and</p> <p>14.1.2. in the event of termination of production of the spare parts:</p> <p>14.1.2.1. Advance notification to the purchaser of the pending termination, in sufficient time to permit the purchaser to procure needed requirements; and</p> <p>14.1.2.2. Following such termination, furnishing at no cost to the purchaser, the blueprints, drawings, and specifications of the spare parts, if requested.</p>
GCC14 SSC 1	Not applicable to this contract
GCC15	15. Warranty
	<p>15.1. The supplier warrants that the goods supplied under the contract are new, unused, of the most recent or current models and that they incorporate all recent improvements in design and materials unless provided otherwise in the contract. The supplier further warrants that all goods supplied under this contract shall have no defect, arising from design, materials, or workmanship (except when the design and/or material is required by the purchaser's specifications) or from any act or omission of the supplier, that may develop under normal use of the supplied goods in the conditions prevailing in the country of final destination.</p>

	<p>15.2. This warranty shall remain valid for twelve (12) months after the goods, or any portion thereof as the case may be, have been delivered to and accepted at the final destination indicated in the contract, or for eighteen (18) months after the date of shipment from the port or place of loading in the source country, whichever period concludes earlier, unless specified otherwise in SCC.</p> <p>15.3. The purchaser shall promptly notify the supplier in writing of any claims arising under this warranty.</p> <p>15.4. Upon receipt of such notice, the supplier shall, within the period specified in SCC and with all reasonable speed, repair or replace the defective goods or parts thereof, without costs to the purchaser.</p> <p>15.5. If the supplier, having been notified, fails to remedy the defect(s) within the period specified in SCC, the purchaser may proceed to take such remedial action as may be necessary, at the supplier's risk and expense and without prejudice to any other rights, which the purchaser may have against the supplier under the contract.</p>
GCC15 SCC 1	Clause 15.1 additionally applies to services supplied and is additionally read in the context of supplying services.
GCC15 SCC 2	Clause 15.2 is amended to read 60 months (not 12 months) and for imports to read 66 months (not 18 months).
GCC16	16. Payment
	<p>16.1. The method and conditions of payment to be made to the supplier under this contract shall be specified in SCC.</p> <p>16.2. The supplier shall furnish the purchaser with an invoice accompanied by a copy of the delivery note and upon fulfilment of other obligations stipulated in the contract.</p> <p>16.3. Payments shall be made promptly by the purchaser, but in no case later than thirty (30) days after submission of an invoice or claim by the supplier.</p> <p>16.4. Payment will be made in Rand unless otherwise stipulated in SCC</p>
GCC16 SCC	Method and conditions of payment are as follows:
GCC16 SCC 1	Payment invoices are required to be submitted within one week after indicated acceptance of each batch. No invoices will be accepted within the inspection period as per GCC 8 and GCC 8 SCC 1.
GCC16 SCC 2	The NRF only accepts invoices supported by signed delivery documents in accordance with this contract as valid payment requests.

GCC16 SCC 3	The other party submits the above invoices to the appointed contract manager for submission to the respective finance unit.
GCC16 SCC 4	The NRF does not settle invoices for outstanding goods or services (e.g. upfront payments or payment on incomplete deliveries). Deviations from this process shall be reviewed on a case-by-case basis, at the time of bid submission only.
GCC17	17. Prices
	17.1. Prices charged by the supplier for goods delivered and services performed under the contract shall not vary from the prices quoted by the supplier in his bid, with the exception of any price adjustments authorized in SCC or in the purchaser's request for bid validity extension, as the case may be.
GCC17 SCC 1	All adjustments to unit prices must be specified on the SBD3.2 and apply in accordance with the terms set in the SBD3.2. Applications for price adjustments must have the documentary evidence set for each adjustment in the SBD3.2 to support of any adjustment. Unit price adjustments will only apply once the NRF has approved in writing the application. Contract management verifies all cost adjustment applications prior to giving approval.
GCC18	18. Contract amendment
	18.1. No variation in or modification of the terms of the contract shall be made except by written amendment signed by the parties concerned.
GCC19	19. Assignment
	19.1. The supplier shall not assign, in whole or in part, its obligations to perform under the contract, except with the purchaser's prior written consent.
GCC20	20. Subcontract
	20.1. The supplier shall notify the purchaser in writing of all subcontracts awarded under this contract if not already specified in the bid. Such notification, in the original bid or later, shall not relieve the supplier from any liability or obligation under the contract
GCC21	21. Delays in supplier's performance
	21.1. Delivery of the goods and performance of services shall be made by the supplier in accordance with the time schedule prescribed by the purchaser in the contract. 21.2. If at any time during performance of the contract, the supplier or its subcontractor(s) should encounter conditions impeding timely delivery of the goods and performance of services, the supplier shall promptly notify the purchaser in writing of the fact of the delay, its likely duration and its

	<p>cause(s). As soon as practicable after receipt of the supplier's notice, the purchaser shall evaluate the situation and may at his discretion extend the supplier's time for performance, with or without the imposition of penalties, in which case the extension shall be ratified by the parties by amendment of contract.</p> <p>21.3. No provision in a contract shall be deemed to prohibit the obtaining of supplies or services from a national department, provincial department, or a local authority.</p> <p>21.4. The right is reserved to procure outside of the contract small quantities or to have minor essential services executed if an emergency arises, the supplier's point of supply is not situated at or near the place where the supplies are required, or the supplier's services are not readily available.</p> <p>21.5. Except as provided under GCC Clause 25, a delay by the supplier in the performance of its delivery obligations shall render the supplier liable to the imposition of penalties, pursuant to GCC Clause 22, unless an extension of time is agreed upon pursuant to GCC Clause 21.2 without the application of penalties.</p> <p>21.6. Upon any delay beyond the delivery period in the case of a supplies contract, the purchaser shall, without cancelling the contract, be entitled to purchase supplies of a similar quality and up to the same quantity in substitution of the goods not supplied in conformity with the contract and to return any goods delivered later at the supplier's expense and risk, or to cancel the contract and buy such goods as may be required to complete the contract and without prejudice to his other rights, be entitled to claim damages from the supplier.</p>				
GCC22	22. Penalties				
	<p>22.1. Subject to GCC Clause 25, if the supplier fails to deliver any or all of the goods or to perform the services within the period(s) specified in the contract, the purchaser shall, without prejudice to its other remedies under the contract, deduct from the contract price, as a penalty, a sum calculated on the delivered price of the delayed goods or unperformed services using the current prime interest rate calculated for each day of the delay until actual delivery or performance. The purchaser may also consider termination of the contract pursuant to GCC Clause 23.</p>				
GCC22 SSC 1	PENALTIES FOR NOT MEETING THE MINIMUM LEVELS SET OUT IN THE SERVICE PERFORMANCE LEVELS EARLIER IN THIS DOCUMENT				
	<table border="1"> <thead> <tr> <th>Service being Measured</th> <th>Penalty where below minimum</th> </tr> </thead> <tbody> <tr> <td>Batch volume delivered</td> <td>No penalties apply. Extra deliveries required to make up the batch sizes to be covered at the Suppliers' cost.</td> </tr> </tbody> </table>	Service being Measured	Penalty where below minimum	Batch volume delivered	No penalties apply. Extra deliveries required to make up the batch sizes to be covered at the Suppliers' cost.
Service being Measured	Penalty where below minimum				
Batch volume delivered	No penalties apply. Extra deliveries required to make up the batch sizes to be covered at the Suppliers' cost.				

	Batch delivery according to schedule	A late penalty of 1% of the batch subtotal cost shall be imposed on the Supplier for each day that the relevant batch is late. This penalty amount is limited to 10% of the batch subtotal cost.
	Quality of manufactured parts	No penalties apply. Costs incurred to replace non-conforming parts shall be at the Suppliers expense.
GCC23	23. Termination for default	
	<p>23.1. The purchaser, without prejudice to any other remedy for breach of contract, by written notice of default sent to the supplier, may terminate this contract in whole or in part:</p> <p>23.1.1. if the supplier fails to deliver any or all of the goods within the period(s) specified in the contract, or within any extension thereof granted by the purchaser pursuant to GCC Clause 21.2;</p> <p>23.1.2. if the Supplier fails to perform any other obligation(s) under the contract; or</p> <p>23.1.3. if the supplier, in the judgment of the purchaser, has engaged in corrupt or fraudulent practices in competing for or in executing the contract.</p> <p>23.2. In the event the purchaser terminates the contract in whole or in part, the purchaser may procure, upon such terms and in such manner as it deems appropriate, goods, works or services similar to those undelivered, and the supplier shall be liable to the purchaser for any excess costs for such similar goods, works or services. However, the supplier shall continue performance of the contract to the extent not terminated.</p> <p>23.3. Where the purchaser terminates the contract in whole or in part, the purchaser may decide to impose a restriction penalty on the supplier by prohibiting such supplier from doing business with the public sector for a period not exceeding 10 years.</p> <p>23.4. If a purchaser intends imposing a restriction on a supplier or any person associated with the supplier, the supplier will be allowed a time period of not more than fourteen (14) days to provide reasons why the envisaged restriction should not be imposed. Should the supplier fail to respond within the stipulated fourteen (14) days the purchaser may regard the intended penalty as not objected against and may impose it on the supplier.</p> <p>23.5. Any restriction imposed on any person by the Accounting Officer / Authority will, at the discretion of the Accounting Officer / Authority, also be applicable to any other enterprise or any partner, manager, director or other person who wholly or partly exercises or exercised or may exercise</p>	

	<p>control over the enterprise of the first-mentioned person, and with which enterprise or person the first-mentioned person, is or was in the opinion of the Accounting Officer / Authority actively associated.</p> <p>23.6. If a restriction is imposed, the purchaser must, within five (5) working days of such imposition, furnish the National Treasury, with the following information:</p> <p>23.6.1. the name and address of the supplier and / or person restricted by the purchaser;</p> <p>23.6.2. the date of commencement of the restriction</p> <p>23.6.3. the period of restriction; and</p> <p>23.6.4. the reasons for the restriction.</p> <p>These details will be loaded in the National Treasury's central database of suppliers or persons prohibited from doing business with the public sector.</p> <p>23.7. If a court of law convicts a person of an offence as contemplated in sections 12 or 13 of the Prevention and Combating of Corrupt Activities Act, No. 12 of 2004, the court may also rule that such person's name be endorsed on the Register for Tender Defaulters. When a person's name has been endorsed on the Register, the person will be prohibited from doing business with the public sector for a period not less than five years and not more than 10 years. The National Treasury is empowered to determine the period of restriction and each case will be dealt with on its own merits. According to section 32 of the Act the Register must be open to the public. The Register can be perused on the National Treasury website.</p>
GCC24	24. Anti-dumping and countervailing duties
	<p>24.1. When, after the date of bid, provisional payments are required, or anti-dumping or countervailing duties are imposed, or the amount of a provisional payment or anti-dumping or countervailing right is increased in respect of any dumped or subsidized import, the STATE is not liable for any amount so required or imposed, or for the amount of any such increase. When, after the said date, such a provisional payment is no longer required or any such anti-dumping or countervailing right is abolished, or where the amount of such provisional payment or any such right is reduced, any such favourable difference shall on demand be paid forthwith by the contractor to the STATE or the STATE may deduct such amounts from moneys (if any) which may otherwise be due to the contractor in regard to supplies or services which he delivered or rendered, or is to deliver or render in terms of the contract or any other contract or any other amount which may be due to him</p>
GCC25	25. Force Majeure
	<p>25.1. Notwithstanding the provisions of GCC Clauses 22 and 23, the supplier shall not be liable for forfeiture of its performance security, damages, or termination for default if and to the extent that his delay in performance or</p>

	<p>other failure to perform his obligations under the contract is the result of an event of force majeure.</p> <p>25.2. If a force majeure situation arises, the supplier shall promptly notify the purchaser in writing of such condition and the cause thereof. Unless otherwise directed by the purchaser in writing, the supplier shall continue to perform its obligations under the contract as far as is reasonably practical, and shall seek all reasonable alternative means for performance not prevented by the force majeure event.</p>
GCC26	26. Termination for insolvency
	<p>26.1. The purchaser may at any time terminate the contract by giving written notice to the supplier if the supplier becomes bankrupt or otherwise insolvent. In this event, termination will be without compensation to the supplier, provided that such termination will not prejudice or affect any right of action or remedy which has accrued or will accrue thereafter to the purchaser.</p>
GCC27	27. Settlement of disputes
	<p>27.1. If any dispute or difference of any kind whatsoever arises between the purchaser and the supplier in connection with or arising out of the contract, the parties shall make every effort to resolve amicably such dispute or difference by mutual consultation.</p> <p>27.2. If, after thirty (30) days, the parties have failed to resolve their dispute or difference by such mutual consultation, then either the purchaser or the supplier may give notice to the other party of his intention to commence with mediation. No mediation in respect of this matter may be commenced unless such notice is given to the other party.</p> <p>27.3. Should it not be possible to settle a dispute by means of mediation, it may be settled in a South African court of law.</p> <p>27.4. Mediation proceedings shall be conducted in accordance with the rules of procedure specified in the SCC.</p> <p>27.5. Notwithstanding any reference to mediation and/or court proceedings herein,</p> <p>27.5.1. the parties shall continue to perform their respective obligations under the contract unless they otherwise agree; and</p> <p>27.5.2. the purchaser shall pay the supplier any monies due the supplier.</p>
GCC28	28. Limitation of liability
	<p>28.1. Except in cases of criminal negligence or wilful misconduct, and in the case of infringement pursuant to Clause 6;</p> <p>28.1.1. the supplier shall not be liable to the purchaser, whether in contract, tort, or otherwise, for any indirect or consequential</p>

	<p>loss or damage, loss of use, loss of production, or loss of profits or interest costs, provided that this exclusion shall not apply to any obligation of the supplier to pay penalties and/or damages to the purchaser; and</p> <p>28.1.2. the aggregate liability of the supplier to the purchaser, whether under the contract, in tort or otherwise, shall not exceed the total contract price, provided that this limitation shall not apply to the cost of repairing or replacing defective equipment.</p>
GCC29	29. Governing language
	<p>29.1. The contract shall be written in English. All correspondence and other documents pertaining to the contract that is exchanged by the parties shall also be written in English.</p>
GCC30	30. Applicable law
	<p>30.1. The contract shall be interpreted in accordance with South African laws, unless otherwise specified in SCC.</p>
GCC31	31. Notices
	<p>31.1. Every written acceptance of a bid shall be posted to the supplier concerned by registered or certified mail and any other notice to him shall be posted by ordinary mail to the address furnished in his bid or to the address notified later by him in writing and such posting shall be deemed to be proper service of such notice</p> <p>31.2. The time mentioned in the contract documents for performing any act after such aforesaid notice has been given, shall be reckoned from the date of posting of such notice</p>
GCC32	32. Taxes and duties
	<p>32.1. A foreign supplier shall be entirely responsible for all taxes, stamp duties, license fees, and other such levies imposed outside the purchaser's country.</p> <p>32.2. A local supplier shall be entirely responsible for all taxes, duties, license fees, etc., incurred until delivery of the contracted goods to the purchaser.</p> <p>32.3. No contract shall be concluded with any bidder whose tax matters are not in order. Prior to the award of a bid the Department must be in possession of a tax clearance certificate, submitted by the bidder. This certificate must be an original issued by the South African Revenue Services</p>
GCC33	33. National Industrial Participation Programme
	<p>33.1. The NIP Programme administered by the Department of Trade and Industry shall be applicable to all contracts that are subject to the NIP obligation.</p>

GCC34	34. Prohibition of restrictive practices
	<p>34.1. In terms of section 4 (1) (b) (iii) of the Competition Act No. 89 of 1998, as amended, an agreement between, or concerted practice by, firms, or a decision by an association of firms, is prohibited if it is between parties in a horizontal relationship and if a bidder (s) is / are or a contractor(s) was / were involved in collusive bidding (or bid rigging).</p> <p>34.2. If a bidder(s) or contractor(s), based on reasonable grounds or evidence obtained by the purchaser, has / have engaged in the restrictive practice referred to above, the purchaser may refer the matter to the Competition Commission for investigation and possible imposition of administrative penalties as contemplated in the Competition Act No. 89 of 1998.</p> <p>34.3. If a bidder(s) or contractor(s), has / have been found guilty by the Competition Commission of the restrictive practice referred to above, the purchaser may, in addition and without prejudice to any other remedy provided for, invalidate the bid(s) for such item(s) offered, and / or terminate the contract in whole or part, and / or restrict the bidder(s) or contractor(s) from conducting business with the public sector for a period not exceeding ten (10) years and / or claim damages from the bidder(s) or contractor(s) concerned.</p>
BID SCC 1	Intellectual property provided in the bid invitation The ownership and intellectual property rights of all designs, specifications, programming code and all other documentation provided by the NRF to the Bidder, both successful and unsuccessful, remain the property of the NRF
BID SCC 2	Intellectual property contained in the deliverables The ownership and intellectual property rights of all designs, specifications, programming code and all other documentation required as part of the delivery to the NRF reside with the NRF.
BID SCC 3	Third Party Warranty Where the contracted party sources goods or services from a third party, the contracted party warrants that all financial and supply arrangements are agreed between the contracted party and the third party.
BID SCC 4	Third Party Agreements No agreement between the contracted party and the third party is binding on the NRF.
BID SCC 5	Contracted Party Due Diligence The NRF reserves the right to conduct supply chain due diligence at any time during the contract period including site visits.

<p>BID SCC 6</p>	<p>Jigs, Tools, Templates, Etc.</p> <p>Unless otherwise agreed, all jigs, tools, templates and similar equipment which may be necessary for the execution of this contract at the NRF's premises shall on completion or cancellation of the contract become property of the NRF provided that the NRF has paid therefore. In such event, the said equipment shall be delivered at the premises of the NRF by the contracted supplier, properly marked with the contract and the relevant code number as supplied by the NRF for the finished items.</p>
<p>BID SCC 7</p>	<p>Copyright and Intellectual Property</p> <p>All background intellectual property shall be deemed to invest in and remain the sole property if the party that contributed same to this contract and/or disclosed the same to the NRF.</p> <p>The contracted supplier hereby grants the NRF a fully paid up, irrevocable, non-exclusive, and transferable licence to use its background intellectual property including the right to sub-licence to third parties in perpetuity and to the extent that shall reasonably be required by the NRF for the exploitation of the contract intellectual property and to enable the NRF to obtain the full benefit of the contract intellectual property.</p> <p>The parties agree that all right, title, and interest in the contract intellectual property rightly invests in the NRF and to give effect to the foregoing:</p> <ol style="list-style-type: none"> 1. The contracted supplier hereby assigns all rights, titles, and interests in and to the contract intellectual property that it may own to the NRF and the NRF hereby accepts such assignment, and 2. The contracted supplier undertakes to assign in writing to the NRF all contract intellectual property and which may invest in the contracted supplier. <p>The contracted supplier shall ensure that the contract intellectual property is kept confidential and shall fulfil its confidentiality obligations as set out in this document.</p> <p>The contracted supplier shall assist the NRF in obtaining statutory protection for the contract intellectual property at the expense of the NRF wherever the NRF may choose to obtain such protection. The contracted party shall procure where necessary the signatures of its personnel for the assignment of the contract intellectual property to the NRF, or as the NRF may direct, and to support the NRF, or its nominee, in the prosecution and enforcement thereof in any country in the world.</p> <p>The contracted supplier hereby irrevocably appoints the NRF to be its true and lawful agent in its own name, to do such acts, deeds, and things and to execute deeds, documents and forms which the NRF, in its absolute discretion, requires in order to give effect to the terms of this clause.</p>

	<p>The rights and obligations set out in this clause shall service termination of this contract indefinitely.</p>
<p>BID SCC 8</p>	<p>Confidentiality</p> <p>The recipient of confidential information shall be careful and diligent so as not to cause any unauthorised disclosure or use of the confidential information, in particular, during its involvement with the NRF and after termination of its involvement with the NRF, the recipient shall not:</p> <ol style="list-style-type: none"> 1. Disclose the confidential information, directly or indirectly, to any person or entity, without the NRF's prior written consent. 2. Use, exploit or in any other manner whatsoever apply the confidential information for any other purpose whatsoever, other than for the execution of the contract and the delivery of the deliverables or 3. Copy, reproduce or otherwise publish confidentiality information except as strictly required for the execution of the contract. <p>The recipient shall ensure that any employees, agents, directors, contractors, service providers, and associates which may gain access to the confidential information are bound by agreement with the recipient, not to</p> <ol style="list-style-type: none"> 1. Disclose the confidential information to any third party, or 2. Use the confidential information otherwise than as may be strictly necessary for the execution of the contract, <p>Both during the term of their associations with the recipient and after termination of their respective associations with the recipient.</p> <p>The recipient shall take all such steps as may be reasonably necessary to prevent the confidential information from falling into the hands of any unauthorised third party.</p> <p>The undertakings set out in this clause shall not apply to confidential information, which the recipient is able to prove:</p> <ol style="list-style-type: none"> 1. Was in the possession of the recipient prior to its involvement with the NRF; 2. Is now or hereafter comes into the public domain other than by breach of this contract by the recipient; 3. Was lawfully received by the recipient from a third party acting in good faith having a right of further disclosure and who do not derive the same directly or indirectly from the NRF, or 4. Was independently developed by the recipient prior to its involvement with the NRF; or 5. Is required by law to be disclosed by the recipient, but only to the extent of such order and the recipient shall inform the NRF of such requirement prior to any disclosure.

The recipient shall within one (1) month of receipt of a written request from the NRF to do so, return to the NRF all material embodiments, whether in documentary or electronic form. Of the confidential information including but not limited to:

1. All written disclosures received from the NRF;
2. All written transcripts of confidential information disclosed verbally by the NRF;
and
3. All material embodiments of the contract intellectual property.

The recipient acknowledges that the confidential information is being made available solely for the execution of the contract and for no other purpose whatsoever and that the confidential information would not have been made available to the recipient, but for the obligations of confidentiality agreed to herein.

Except as expressly herein provided, this contract shall not be construed as granting or confirming, either expressly or impliedly any rights, licences or relationships by furnishing of confidential information by either party pursuant to this contract.

REFERENCE LETTER TEMPLATE – ANNEXURE A

Bidder's Letterhead

We are submitting a bid for the contract described below. We appreciate your assistance and effort in completing on your letterhead the reference as set out below on your experience with us.

Referee Letterhead	<u>Referee Legal Name</u>		
<u>REFERENCE ON COMPANY [INSERT BIDDER NAME]</u>			
Bid Number:	SKA SA HERA 001/2017		
Bid Description			
THE SUPPLY, MANUFACTURE AND DELIVERY OF PVC PARTS OVER FOUR STAGED DELIVERIES TO THE SKA SA LOSBERG SITE NEAR THE TOWN OF CARNARVON, NORTHERN CAPE			
Describe the service/work the above bidder provided to you below:			
Criteria	Needs improvement	Meets requirements	Exceeds requirements
Professionalism			
Overall ease of communication			
Overall satisfaction with bidder			
Satisfaction with quality of work			
Satisfaction with lead times / time to complete work			
Reliability			

Overall Impression			
Please provide any other comments you believe would be useful			
No. of times used in past year		Would you use the bidder again?	YES/NO
Completed by:			
Signature:			
Company Name:			
Contact Telephone Number:			
Date:			
Company Stamp:			

BID SUBMISSION CERTIFICATE FORM - (SBD 1)

	I hereby undertake to supply all or any of the goods, works, and services described in this procurement invitation to the NRF in accordance with the requirements and specifications stipulated in this Bid Invitation document at the price/s quoted.	
	My offer remains binding upon me and open for acceptance by the NRF during the validity period indicated and calculated from the closing time of Bid Invitation.	
	The following documents are deemed to form and be read and construed as part of this offer / bid even where integrated in this document:	
	Invitation to Bid (SBD 1)	Specification(s) set out in this Bid Invitation inclusive of any annexures thereto
	Bidder's responses to this invitation as attached to this document	Pricing Schedule(s) (SBD3) including detailed schedules attached
		CSD / Tax clearance letter
	Declaration of Interest (SBD4);	Independent Price Determination (SBD 9)
	Preference (SBD 6.1) claims for Broad Based Black Economic Empowerment Status Level of Contribution in terms of the Preferential Procurement Regulations 2011 (SBD6.1) and the BBEE certificate	
	Declaration of Bidder's past SCM practice (SBD 8)	Conditions of contract as set out in this document (GCC)
	NIPP Obligations (SBD 5) where applicable	Local Content Certification (SBD 6.2) where applicable
	I confirm that I have satisfied myself as to the correctness and validity of my offer / bid in response to this Bid Invitation; that the price(s) and rate(s) quoted cover all the goods, works and services specified in the Bid Invitation; that the price(s) and rate(s) cover all my obligations and I accept that any mistakes regarding price(s) and rate(s) and calculations will be at my own risk.	
	I accept full responsibility for the proper execution and fulfilment of all obligations and conditions devolving on me in terms of this Bid Invitation as the principal liable for the due fulfilment of the subsequent contract if awarded to me.	
	I declare that I have had no participation in any collusive practices with any Bidder or any other person regarding this or any other Bid.	

	I certify that the information furnished in these declarations (SBD4, SBD6.1, SBD 6.2 where applicable, SBD5, SBD8, SBD9) is correct and I accept that the NRF may reject the Bid or act against me should these declarations prove to be false.
	I confirm that I am duly authorised to sign this offer/ bid response.
NAME (PRINT)	
CAPACITY	
SIGNATURE	
Witness 1	
NAME	
SIGNATURE	
Witness 2	
NAME	
SIGNATURE	
DATE	



Client : NRF (National Research Foundation)
Project : HERA
Type : DRAWING DATAPACK

PVC MANUFACTURING DATAPACK FOR BID INVITATION NO.

SKA SA HERA 001/2017

Document number H0010-2000-001
Revision 1
Classification..... Commercial in Confidence
Author K A Rosie
Date 17 March 2017

DOCUMENT APPROVAL

	Name	Designation	Affiliation	Date	Signature
Submitted	K Rosie	Design Engineer	SKA SA	<i>Kathryn Rosie</i> Kathryn Rosie (Mar 29, 2017)	
Reviewed	Z Halday	HERA Project Manager	SKA SA	<i>Ziyad Halday</i> Ziyad Halday (Mar 31, 2017)	
Approved	D DeBoer	HERA Project Manager	UCB	<i>David DeBoer</i> David DeBoer (Mar 30, 2017)	

DOCUMENT HISTORY

Revision	Date Of Issue	ECN Number	Comments
1	17 March 2017	N/A	1 st Release for Bid Purposes / Information Only

DOCUMENT SOFTWARE

	Package	Version	Filename
CAD Package	Autodesk Inventor	2017	SKA_SA.idw

COMPANY DETAILS

Name	Square Kilometre Array South Africa
Physical/Postal Address	Third Floor The Park Park Road Pinelands 7405
Tel.	+27 21 506 7300
Fax.	+27 21 506 7375
Website	www.ska.ac.za

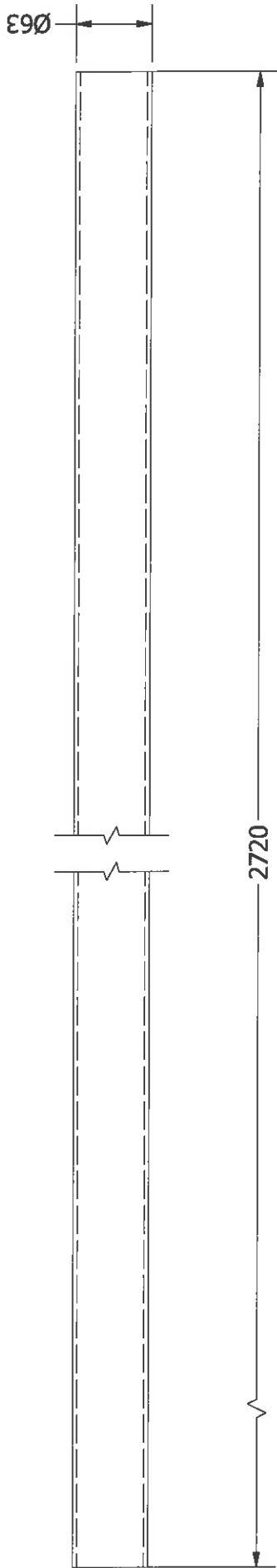

NOTES:

- 1) All dims in mm unless otherwise stated
- 2) All tolerances $\pm 1\text{mm}$ unless otherwise stated
- 3) Ends to be square and chamfered for solvent weld connection
- 4) NB: Ensure that the ends of the pipe do not exceed the specified diameter

MATL: DIA. 63mm CLASS 12 uPVC

This document is the property of SKA SA and shall not be used, reproduced, transmitted or disclosed without prior written permission.

ISSUED FOR INFORMATION ONLY

DRAWN KA ROSIE	2016/04/11	 	
CHECKED			
APPROVED			

SKA SA - HERA PROJECT

TITLE

HORIZONTAL HUB SPAR

SIZE
A4

DWG NO
H1HU

REV
B

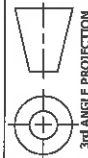

SCALE
1:5



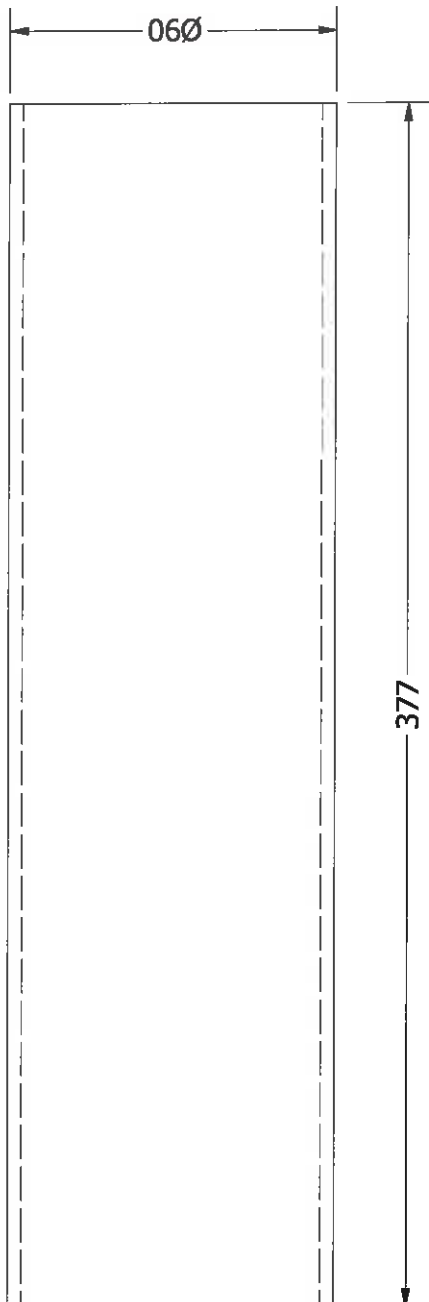

SHEET 1 OF 1



NOTES:

1. All dims in mm unless otherwise stated
2. All tolerances ±1mm unless otherwise stated
3. NB: Ensure that the ends of the pipe do not exceed the specified diameter

MATL: DIA. 90mm CLASS 9 uPVC

This document is the property of SKA SA and shall not be used, reproduced, transmitted or disclosed without prior written permission.		ISSUED FOR INFORMATION ONLY	
DRAWN	2016/04/21	SKA SA - HERA PROJECT TITLE HUB SLEEVE	
KA ROSIE			
CHECKED		 	DWG NO H1HS
APPROVED			SIZE A4
		SCALE 1 / 2	3rd ANGLE PROJECTION 
			REV B
			SHEET 1 OF 1

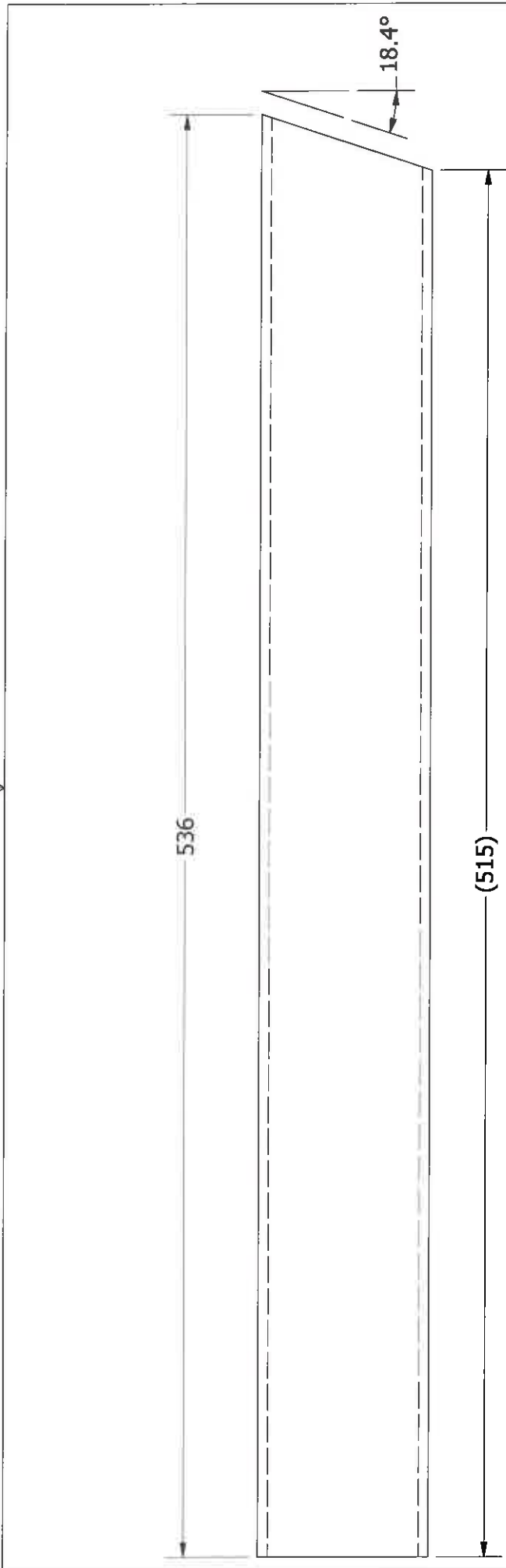

NOTES:

- 1) All dimensions in mm unless otherwise specified
- 2) All linear tolerances $\pm 1\text{mm}$ unless otherwise specified
- 3) All angular tolerances within 0.2° unless otherwise specified

MATL: 63mm CLASS 12 UPVC

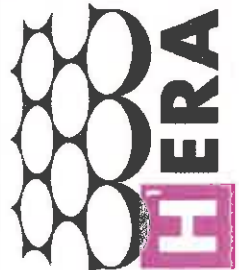
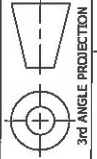
This document is the property of SKA SA and shall not be used, reproduced, transmitted or disclosed without prior written permission.		ISSUED FOR INFORMATION ONLY	
DRAWN KA ROSIE	2016/06/03	SKA SA - HERA PROJECT	
CHECKED			
APPROVED		TITLE SUPPORT SPAR UPRIGHT	
			
SIZE A4	DWG NO H1PV-P	REV C	
SCALE 1 / 2.1		SHEET 1 OF 1	

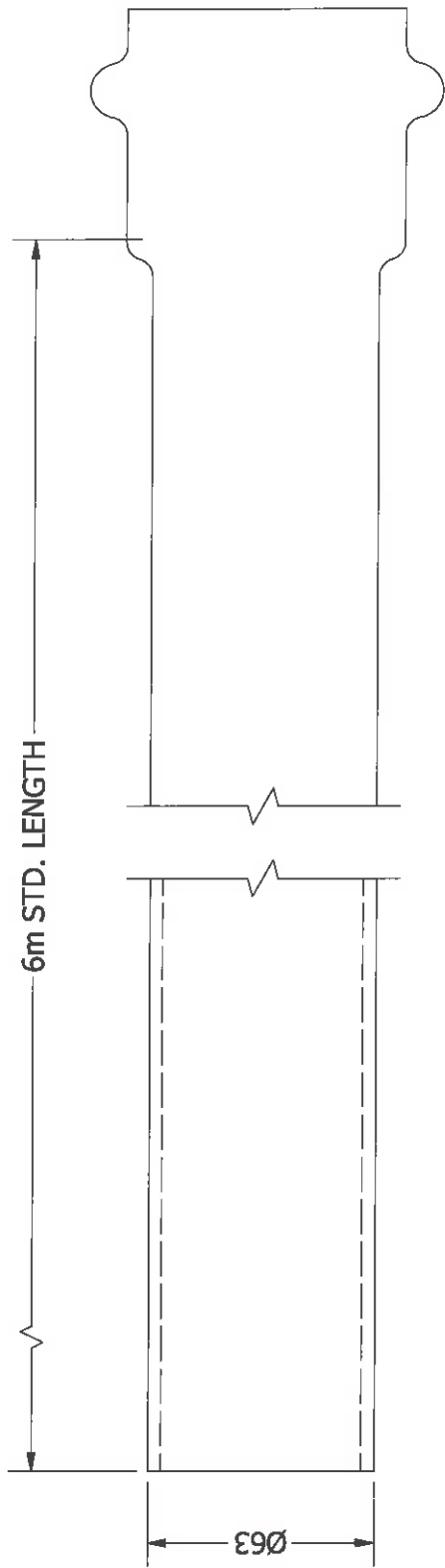

MATL: 63mm DIA. CLASS 12 uPVC, 6m STD. LENGTH

NOTES:

1. All dimensions in millimetres unless otherwise specified
2. All tolerances ±1mm unless otherwise specified
3. One end to be square and chamfered for solvent weld connection
4. Other end to contain unmodified bell-shaped socket

This document is the property of SKA SA and shall not be used, reproduced, transmitted or disclosed without prior written permission.

DRAWN	2017/03/09
KA ROSIE	
CHECKED	
APPROVED	

SKA SA - HERA PROJECT

TITLE

LONG SPAR



SIZE	DWG NO	REV
A4	H1RF-L	A
SCALE	1 / 2	SHEET 1 OF 1

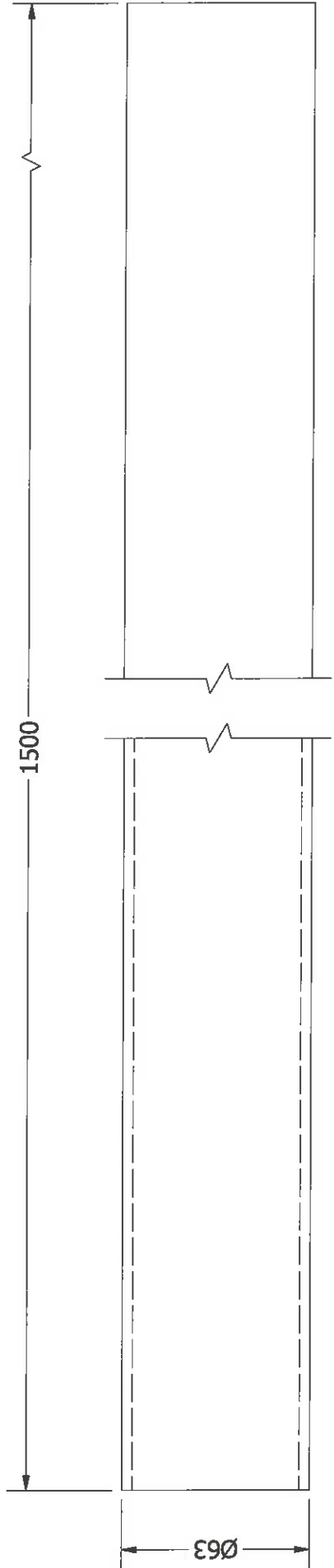

NOTES:

1. All dimensions in millimetres unless otherwise specified
2. All tolerances $\pm 1\text{mm}$ unless otherwise specified
3. Both ends to be square and chamfered for solvent weld connection

MATL: 63mm DIA. CLASS 12 uPVC

This document is the property of SKA SA and shall not be used, reproduced, transmitted or disclosed without prior written permission.

DRAWN	2017/03/09	ISSUED FOR INFORMATION ONLY
KA ROSIE		SKA SA - HERA PROJECT
CHECKED		

TITLE

SHORT SPAR

SIZE	DWG NO	REV
A4	H1RF-S	A

3rd ANGLE PROJECTION

SCALE 1 / 2



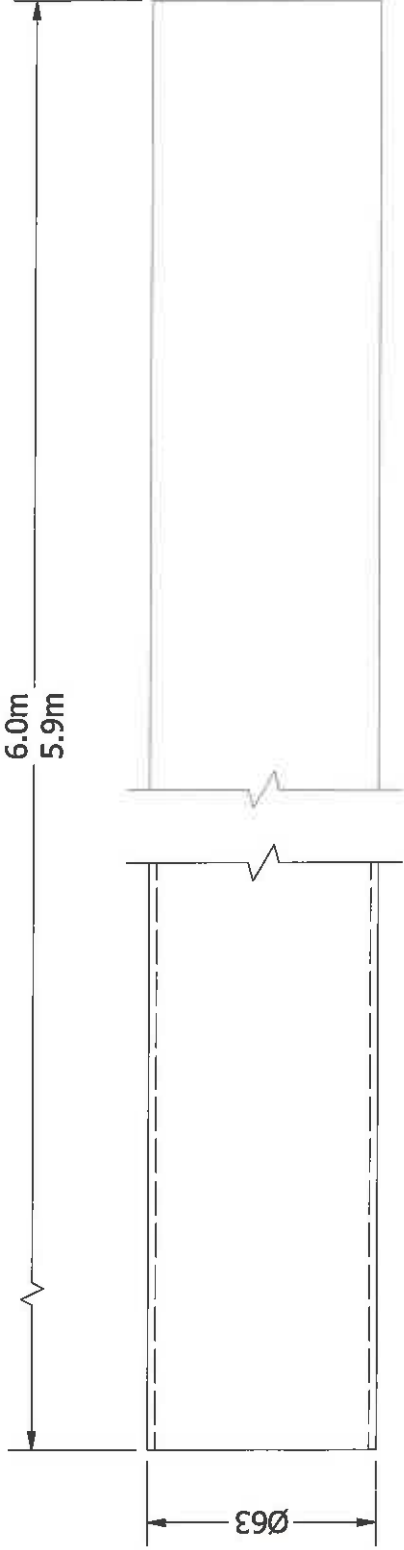

NOTES:

1. All dimensions in millimetres unless otherwise specified
2. All tolerances $\pm 1\text{mm}$ unless otherwise specified
3. Both ends to be square and chamfered for solvent weld connection.

MATL: 63mm DIA. CLASS 12 mPVC, 6m STD. LENGTH

This document is the property of SKA SA and shall not be used, reproduced, transmitted or disclosed without prior written permission.

ISSUED FOR INFORMATION ONLY

DRAWN	2017/03/09	 
KA ROSIE		
CHECKED		
APPROVED		

SKA SA - HERA PROJECT

TITLE

INTERMEDIATE SPAR

SIZE	DWG NO	REV
A4	H1RI	A
SCALE	1 / 2	SHEET 1 OF 1

NOTES:

1. All dimensions in mm unless otherwise specified
2. All tolerances $\pm 1\text{mm}$ unless otherwise specified
3. Final length of Item 2 depends on insertion length of Item 1

PARTS LIST

ITEM	QTY	PART #	DESCRIPTION
1	1	COTS	63mm uPVC Solvent Weld Equal Tee
2	2	H1RC-C	Cross Piece, cut according to dims

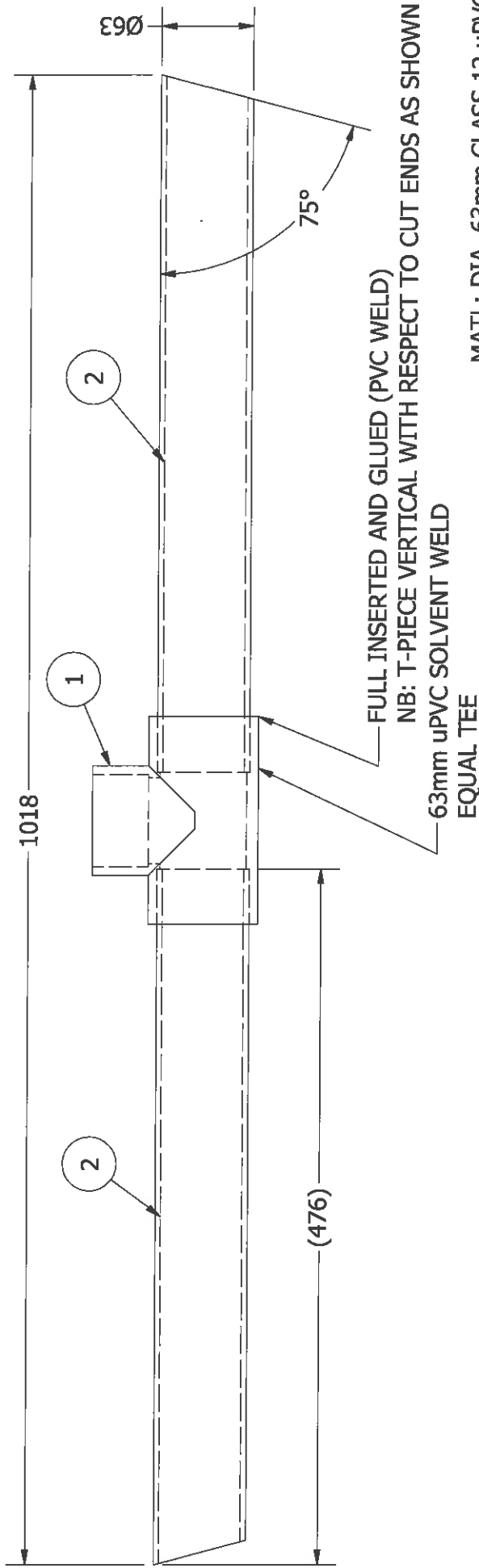

MATL: DIA. 63mm CLASS 12 uPVC

This document is the property of SKA SA and shall not be used, reproduced, transmitted or disclosed without prior written permission.

ISSUED FOR INFORMATION ONLY

DRAWN	2016/06/07
KA ROSIE	
CHECKED	
APPROVED	

SKA SA - HERA PROJECT

TITLE

CROSS-SPAR SUB ASSEMBLY



SIZE	DWG NO	REV
A4	H1RC	D
SCALE	1 / 4	
SHEET 1 OF 1		

NOTES:

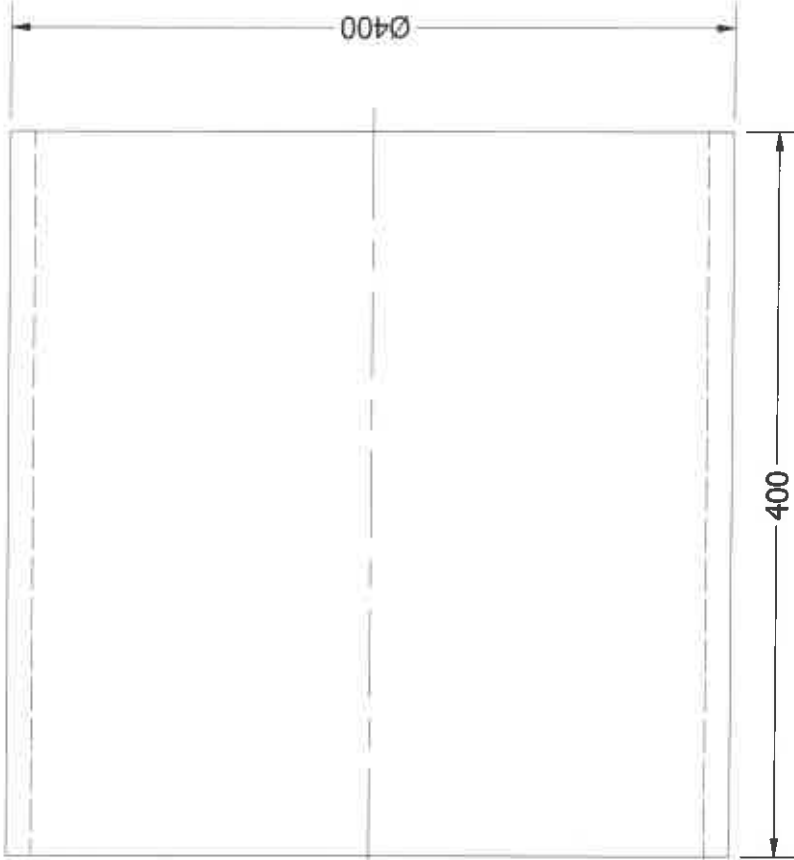

1. All dimensions in mm unless otherwise specified
2. All linear tolerances ± 1 mm unless otherwise specified



400

Ø400

MATL: DIA. 400mm CLASS 9 uPVC

This document is the property of SKA SA and shall not be used, reproduced, transmitted or disclosed without prior written permission.		ISSUED FOR INFORMATION ONLY	
DRAWN KA ROSIE CHECKED	2017/03/16	SKA SA - HERA PROJECT	
APPROVED D DEBOER		TITLE POST BASE FORMS	
		SIZE A4	DWG NO H1PS-F
		SCALE 1/4	REV A
		SHEET 1 OF 1	

1/4

SHEET 1 OF 1